



RM-1

Repeater Maker

Manual Revision: 2010-02-10

**Covers Firmware Revisions:
RM-1: 3.0 & Higher**

SPECIFICATIONS

Operating Voltage	+5.5-15 VDC
Operating Current	3 mA
Operating Temperature	-30 - +60 C
PTT Output Current	200 mA
Horn Output Current	200 mA
Disable Output	200 mA
Input Level	25-500 mV RMS
Input Impedance	100 K Ω
Audio Output Level	1V RMS
Audio Output Impedance	10K Ω /22 K Ω
Dimensions	2.4" L x 1.9" W x 0.4" H

GENERAL INFORMATION

Midian's RM-1 connects between 2 two-way radios to make them into a cost-effective repeater. This product is ideal for use as a permanent low cost repeater by public safety and amateur radio operators or for use as a temporary repeater for search and rescue operations. Two RM-1 modules can be used to create a cross-band repeater. The RM-1 generates Morse ID and also incorporates a DTMF decoder for the following functions:

1. Repeater enable and disable allows for the system administrator to send separate DTMF enable and disable commands to the RM-1.
2. Authorized user access code causes the RM-1 to allow users sending this code to access the repeater.
3. Hang time cancel code is used when the RM-1 is programmed with a long hang time. The hang time cancel code when sent will cancel the rest of the hang time once the code is received and the transmission ends.

PRODUCT PROGRAMMING

For programming via a keypad, please reference the Keypad Programming section.

Midian's RM-1 is programmable using the KL-3 programmer. Please reference the KL-3 manual for setup instructions of the KL-3 software and hardware. From the product selection screen on the KL-3 software, select the RM-1 from the list and click OK.

Set the parameters of the RM-1 to fit the application. If any clarifications on a feature are required, move the mouse cursor over the feature name until the question mark appears and right click, a definition of the feature will be shown.

After entering the parameters, save the file by going to File - Save As. Enter the file name in the File Name block and click Save. Saving the file will allow for quick and easy reprogramming of units.

Connect the Orange/White wire to the Green KL-3 lead and the Black wire to a common ground with the KL-3's Black lead. The Yellow clip lead is not used with these products, as the unit is non-readable.

Ground the PTT Input (Green/White Wire); turn on power, and within 5 seconds click "Program Unit" in the menu bar to send the file to the unit. Remove the ground from the PTT Input after programming.

KEYPAD PROGRAMMING

Programming is accomplished using the KL-3 programmer or from Midian's Keypad Option D (12 button row/column type keypad). Midian recommends using the KL-3 for greater ease in programming. If using the keypad for programming Midian recommends connecting the speaker output to hear the programming tones. Please reference the hardware installation section for connecting the speaker output.

To enter programming mode type the following sequence:

27182818284

The unit will beep 3 times to confirm entry into programming mode.

To program registers 01-02 enter * followed by the register number (*01 or *02) the desired Morse ID sequence and then the # key. When in alphanumeric programming mode, pressing a button once selects the first character on the key and generates one beep, pressing the key twice selects the second character on the key and generates two beeps and pressing the key three times selects the third character on the key and generates three beeps. Once a desired character is entered press the * key to confirm the character. Please reference the programming worksheets at the end of this manual for the key layout. For example to program MIDIAN in register 01 you would press *0164443444266# If the register is successfully programmed the unit will beep 2 times.

To program registers 03-11, enter the desired information plus *nn, where nn equals the register number. If all entries in a register are not completed, trailing zeros will be automatically entered. Extra digits will be ignored. If the register is successfully programmed the unit will beep 2 times. If during entry of the register's parameters a mistake is made, before *nn is pressed, entering the # key will clear the register, so the register may be programmed properly.

If a register is not being used enter #*nn. The "#" key acts as a clear command.

To exit programming mode type the following sequence:

***00**

Upon exiting the programming mode the unit should respond with a long beep and resume normal operation.

The following text describes each of the individual registers and how they can be programmed.

Register 01: Station ID 1: This field can be programmed with a Morse ID message up to 16 alphanumeric characters in length. This is selected station ID when the Orange/White wire is floating.

Register 02: Station ID 2: This field can be programmed with a Morse ID message up to 104 alphanumeric characters in length. This is selected station ID when the Orange/White wire is grounded.

Register 03: Morse ID Control

Register 03A: Morse Tone Frequency: The Morse tone frequency is programmable from 0001 to 3000 Hz in one-cycle increments. FCC rules state that the frequency shall be 800 – 1200 Hz.

Register 03B: Words Per Minute: The speed is programmable from 01 to 99 WPM FCC rules part 90.423 states that the transmission rate shall be between 20 and 25 WPM.

Registers 03C: Repeat Interval: The RM-1 has a repeat interval that is programmable from 01 to 99 minutes. This allows the user to program how often the ID or message is sent. FCC rules state that the station should be identified during each transmission or exchange of transmissions. During periods of continuous operation: once each 15 minutes for commercial, once each 10 minutes for amateur, or once each 30 minutes in public safety and special emergency radio services.

Registers 03D: When to ID: This field is programmable for 0, 1 or 2. Programming a 0 will cause the ID to be sent following the last activation of the CTCSS/DCS inputs, provided the time is met that is programmed in Register 03C (repeat interval). Programming a 1 will cause the ID or message to be sent at the expiration of the repeat interval timer. For example, if register 3C is programmed as 10 and register 3D is programmed as 1, the ID and message will be sent continuously every 10 minutes. This will occur under a conversation if one is in progress when the timer goes off. Programming a 2 will cause the ID or message to be continuously sent for the time programmed in register 3C only when the radio is keyed or during key-up time. This will occur under a conversation if one is in progress when the timer goes off.

Register 04: CTCSS Input Control

Register 04A: CTCSS On/Debounce Time: Program this register from 0.0 to 9.9 seconds. This debounces the CTCSS input if the carrier is experiencing picket fence fading.

Register 04B: CTCSS Off/Debounce Time: Program this register from 0.0 to 9.9 seconds. This performs the same function as register 4A above.

Register 04C: Courtesy Go-Ahead Beep on Loss of CTCSS/DCS Input: This field is programmable for 0, 1 or 2. Programming with a 0 is for no go ahead/courtesy beep. Programming with a 1 gives a go-ahead beep of Morse code E (•). Programming with a 2 gives the courtesy tone of Morse code K (–•–).

Register 04D – CTCSS/DCS Active Polarity: This field can be 0 or 1 and indicates the active polarity the RM-1 is given when the radio is decoding CTCSS or DCS. 0 equals a logic low and a 1 equals a logic high.

Register 04E: Morse ID Lockout Inhibit: This field is programmable for a 0, 1, 2 or 3. The following conditions only apply when the unit is repeating a conversation (register 03D programmed as a 1 or 2) or during the subsequent hang time. Programming this field to a 0 equals no inhibit. Morse ID will go out under the voice at FCC specified 40% of modulation. Programming a 0 will cause the unit to ID after the repeat interval time in register 3C has expired regardless of whether or not a conversation is in progress.

If programmed for a 1 the RM-1 locks out with an active CTCSS/DCS input and is based on CTCSS debounce in register 04B. Programming a 1 prevents the ID from going out when a conversation is in progress. Programming a 2 prevents the Morse ID from going out during the hang time period programmed in register 5A. It will ID after PTT is finished. Programming this field to a 3 turns off both IDs and the unit will never send either station ID.

Register 05: PTT Output Control

Register 05A: Repeater Hang Time: This register is programmable for 000-999 seconds and sets how many seconds the repeater's transmitter will stay keyed after loss of the CTCSS/DCS input. Normally this is programmed for 2 to 7 seconds. If using the RM-1 to set up numerous repeaters in sequence with DTMF access, the repeater could be set up to have a long hang time so that it does not have to be reaccessed if someone stops to think and drops the carrier or CTCSS for too long. At the end of conversation a DTMF command can be sent to immediately knock down all sequenced repeaters using register 09 (hang time cancel code).

Register 05B: Repeater Time Out Timer: This register is programmable for 000-999 seconds. If programmed to 000 this function is off. Programming from 001 – 999 seconds will set the repeater to drop out after the number of seconds programmed in this register. Time out Timer is designed to limit conversational length.

Register 05C: Key-up Delay: This field is programmable for 0.0 to 9.9 seconds, which allows for a key-up delay time before the ID or message is sent. This gives receiving units with CTCSS decoders time to unsquelch before any Morse code is transmitted.

Register 05D: PTT Output Active Polarity: This register is programmable for 0 (logic low) or 1 (logic high) and programs the active polarity of the PTT circuit. Virtually all mobile radios employ logic low (negative polarity) to key a radio transmitter. If you run into a unit using positive polarity (logic high) it may be necessary to install a pull-up resistor to 5 V on the PTT wire, if one is not already in the radio's PTT circuit. Then program to positive polarity. The white PTT out lead employs an open collector transistor with no pull-up resistor.

Register 06: Channel Busy Control: All items in this register are always active if connected.

Register 06A: COR Loss Delay Before ID: This programs for 0.0 to 9.9 seconds how long before the Morse ID will transmit after COR loss assuming the repeat interval in register 03C has expired.

Register 06B: COR Active Polarity: This field can be 0 or 1 and indicates the active polarity the RM-1 is given when the radio is receiving. 0 equals a logic low and a 1 equals a logic high.

Register 06C: Inhibit Line Loss Delay Before ID: This programs for 0.0 to 9.9 seconds how long before the Morse ID will transmit after Inhibit loss assuming the repeat interval in register 03C has expired.

Register 06D: Inhibit Line Active Polarity: This field can be 0 or 1 and indicates the active polarity the RM-1 is given when the secondary receiver is receiving. 0 equals a logic low and a 1 equals a logic high.

Register 07: DTMF Decode Control

Register 07A: DTMF Interdigit Timeout: This register is programmable from 0.0 to 9.9 seconds. When using manual dialing this register sets the drop out time between valid digit sequences. For manual dialing we recommend 1.0. For automatic number identification on PTT to access the RM-1 use approximately 0.1. This number must be greater than the duty cycle off time between ANI digits. When this interdigit gap time is exceeded the RM-1 considers the next incoming number to be part of a new dialing sequence.

Register 07B: Single Tone Decode Time: This register is programmable from 0.0 to 9.9 seconds. This allows the user to access the RM-1 with a single DTMF digit. We recommend using at least 0.5 in this register to prevent accidental voice talk off of the RM-1's DTMF decoder.

Register 07C: Repeater Maker Disable: This register is no longer used in version 3.0 and higher and should be programmed to a 0.

Register 08: Authorized User Access Code: This register can be a 1-8 digit number for protective access of the RM-1. If no number is programmed here the RM-1 will activate on its CTCSS/DCS input.

Register 09: Hang Time Cancel Code: This ID causes the hang timer to be reset after decoding the sequence. This is useful on multihop repeater systems with long hang times. When the conversation is finished this number can terminate the hang timer.

Register 10: Enable Code: This register if used can be a 1-8 digit number to enable the repeater. When the RM-1 receives the enable command it will transmit an N (–•) in Morse code. If not using the enable/disable commands leave registers 10 and 11 empty.

Register 11: Disable Code: This register if used can be a 1-8 digit number to disable the repeater. When the RM-1 receives the disable command it will transmit an F (••–•) in Morse code. If not using the enable/disable commands leave registers 10 and 11 empty.

HARDWARE INSTALLATION

Be certain to follow standard anti-static procedures when handling any of Midian's products.

P1-1 – Green – TX Audio Out – Connect to the modulator circuit. Use a high impedance point in the radio.

P1-2 - Red - +5.5 – 15 VDC – Connect to switched B+ in the radio.

P1-3 – Brown – Primary RX COR Input – Connect to point in the squelch or CTCSS circuit that changes logic level when carrier is received. This wire is used to hold off the Morse ID if the channel is busy and the unit is programmed for COR loss delay (Register 06A).

P1-4 – Black – Ground – Connect to the nearest ground point. Make sure a common ground exists between both the receiving radio and transmitting radio.

P1-5 – Blue – Programming Beep Audio – This provides annunciated keyboard sidetone for programming via the keypad. Connect to high side of speaker. (Speaker completes ground path for speaker emitter-follower transistor, Q3.) When using 20-40 Ohm speakers, the onboard resistor in series with Q3 should be sufficient. When attaching this lead to a 4-8 Ohm speaker, add a 100-Ohm resistor in series with the lead to limit current.

P1-6 – Orange – RX Audio Input – Connect to an audio point in the receiver, usually the high side of the volume control or discriminator output. When using CTCSS, pick up the audio after the high pass filter.

P1-7 – Yellow – Not connected

P1-8 – Green/White – Program Enable – For programming with the KL-3, this lead should be grounded before power up to force the RM-1 into programming mode.

P1-9 – White – PTT Out – Gives a logic low to the transmitter's PTT to key the transmitter. The PTT transistor, Q6, is rated at 100 mA continuous.

P1-10 – Gray/White – PL Inhibit Line – This output will be taken to ground during Morse Code ID generation. This can be connected to a high-impedance point in the CTCSS/DCS tone transmit audio path, which will short-circuit the audio to ground.

P1-11 – Gray – Primary RX DCS/CTCSS Input – This is the actual control input for the RM-1. It receives a logic level from the radio's CTCSS or DCS decoder. The RM-1 will only repeat when it sees the proper CTCSS decode logic level change. If the radio does not employ CTCSS or DCS connect this to the receiving radio's Carrier Detect and leave the Primary RX COR Input disconnected and program for a logic high on the COR polarity (Register 06). If the COR busy lead is not left disconnected the RM-1 will see a busy condition and will not repeat on straight carrier.

P1-12 – Orange/White – ID Select/Program In – For ID Select, if this input is grounded the first station ID is selected. If the input is floating the second Station ID is selected. For Program In, this lead is connected to the Green lead from the KL-3 programmer.

P1-13 – Violet – Optional Secondary RX Inhibit – A logic low on this input can be used from an auxiliary receiver COR or CTCSS output to inhibit an ID on a repeater system with simplex users operating on the repeater's transmit frequency.

HARDWARE ALIGNMENT

RX Audio Input: R47 and C19 serve as a de-emphasis circuit in case audio is taken directly from the discriminator. If this circuit is not needed C19's ground can be cut to eliminate the circuit. This is shown as an asterik (*) on the board layout under C19 just above the fourth pin of the VR1 regulator. U2A is a high pass filter for removing CTCSS tones from the voice audio.

Neither of these circuits are necessary if the receive audio is picked up after the high pass and after de-emphasis. U2B acts as an audio amplifier its gain is controlled by the ratio of R5 over R4. The gain is a little over 2. If necessary, the feedback resistor R5 could be raised to increase the gain for the received audio.

TX Audio Output: Adjust R22 for 4.5 KHz of deviation on peak voice from the receiver. If the orange RX wire is connected after the receiver's volume control you may want to adjust the volume control in conjunction with R22. FCC rules part 90.425 state that the signal output of the ID signal shall be $40\% \pm 10\%$ of the maximum permissible modulation or deviation. Adjust R19 for 40% of system deviation after adjusting voice modulation.

Morse ID Modulation: Set R19 so that the Morse ID goes out at about 40% of peak modulation (2 KHz wideband, 1 KHz narrowband).

OPERATION

Duplex Repeat:

When the RM-1 sees the COR go active on the primary receiver the RM-1 will look to verify that the COR is not active on the secondary receiver (if connected) and if inactive will assert the PTT Output to key the transmitter and pass the incoming voice from the receiver to the transmitter.

Encoding Morse ID:

When using the keyboard pressing *1 sends the station ID and pressing *2 sends the second ID or message. Pressing # sends solid tone for modulation set up. The # key can also be used to manually send Morse code. Loss of PTT is delayed, so the transmitter does not drop in and out when sending Morse by manual means.

Note: Morse IDs will not be transmitted when the CTCSS/DCS input goes low. If the DTMF decode register 08 has a number in it or if the RM-1 has been disabled. If register 08 is programmed it will also require the access code to turn on the RM-1's PTT output.

DTMF Decode:

The RM-1 is capable of decoding 4 different DTMF codes; authorized user access, hang time cancel, repeater enable and repeater disable.

1. Authorized User Access Code: This is meant so that only users sending the proper DTMF code will be granted access to the repeater. If the proper code is not decoded the RM-1 will not repeat the audio.
2. Hang Time Cancel Code: If the RM-1 is programmed for a long repeater hang time, sending the cancel code will force the RM-1 to cancel the remaining time left on the hang timer.
3. Repeater Enable Code: The repeater enable and disable codes are meant to be used by the system administrator to only have the repeater active when desired.
4. Repeater Disable Code: The repeater enable and disable codes are meant to be used by the system administrator to only have the repeater active when desired.

COR Input:

This input controls two functions, busy lockout and inhibiting the Morse ID. The COR polarity must be programmed for the active carrier polarity of the radio.

1. Busy Lockout: If COR is active on the secondary receiver and the unit tries to encode with busy lockout enabled, the unit will be prevented from keying up.
2. Inhibiting Morse ID: If the channel is busy the RM-1 will hold off sending Morse ID until the COR Loss Delay Before ID times out.

TECHNICAL NOTES

No technical notes are available at this time.

MIDIAN CONTACT INFORMATION

Midian Electronics Inc.
2302 East 22nd Street
Tucson, Arizona 85713 USA

Orders: 1-800-MIDIANS
Phone: 520-884-7981
Fax: 520-884-0422
E-mail: sales@midians.com
Web: www.midians.com

Register 06: Channel Busy Control

06A - COR Loss Delay Before ID (0.0-9.9 seconds)

06B - COR Active Polarity (0 = logic low, 1 = logic high)

06C - Inhibit Loss Delay Before ID (0.0-9.9 seconds)

06D - Inhibit Active Polarity (0 = logic low, 1 = logic high)

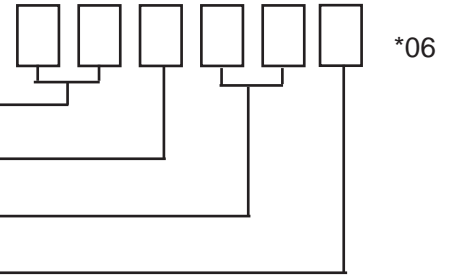

Register 07: DTMF Decode Control

07A - DTMF Interdigit Timeout (0.0-9.9 seconds)

07B - Single Tone Decode Time (0.0-9.9 seconds)

07C - Not Used - Must Equal "0"

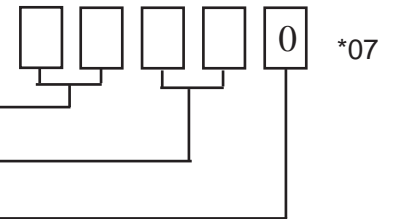

Register 08: Authorized User Access Code



Register 09: Hang Time Cancel Code



Register 10: Repeater Enable Code



Register 11: Repeater Disable Code



To exit programming mode enter: *00

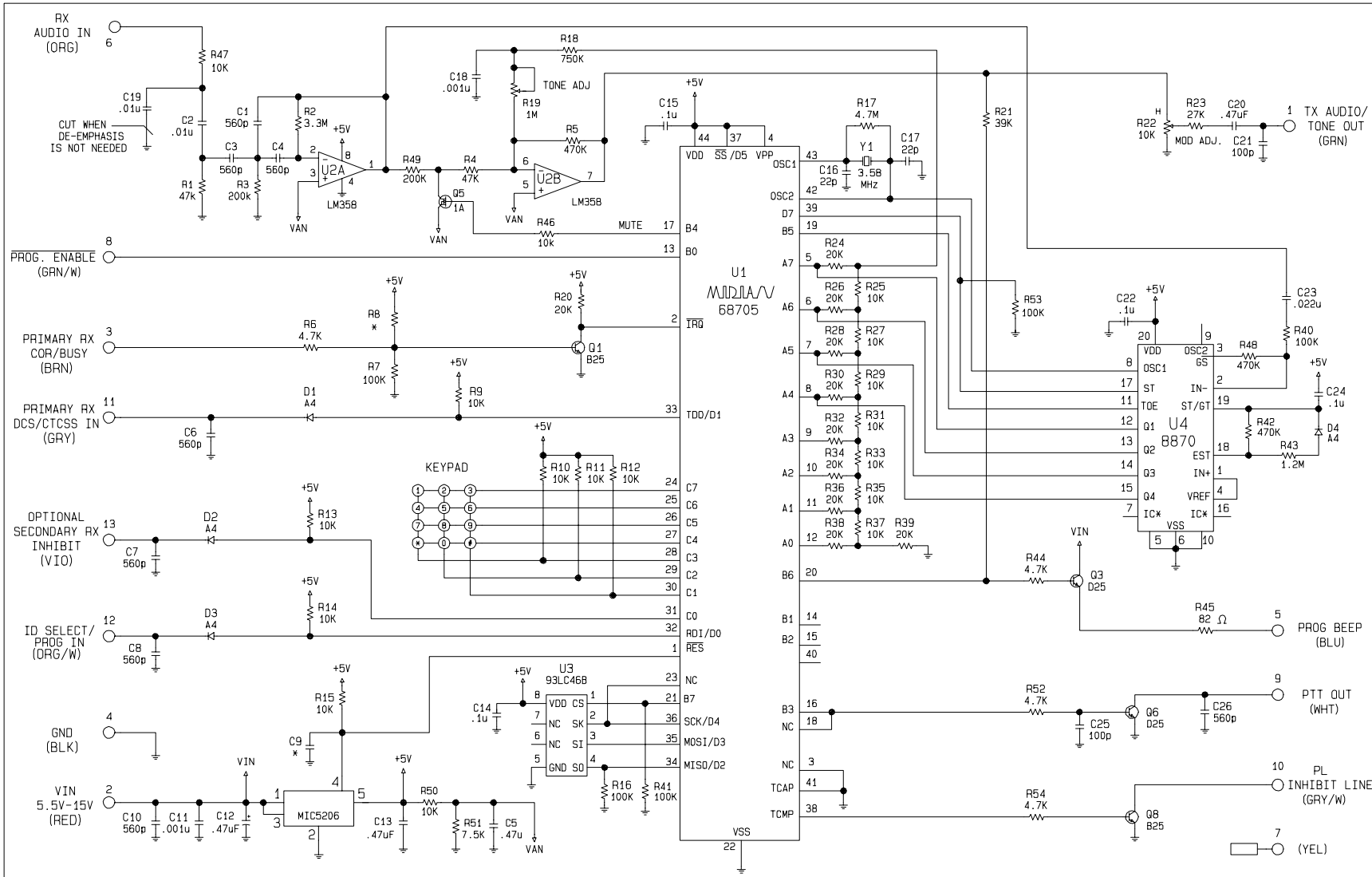

MIDIAN ELECTRONICS			
DATE	JAN 2K	DWN. BY	AB
DESIGN	CJS	REV.	OCT 23/06 AB
		APPR.	

RM-1	REV.	FILE NO.
REPEATER MAKER	C	315C.SCH
SCHEMATIC	SHEET	DWG. NO.
COPYRIGHT © 2006		315-HCD

NOTES: * NOT INSTALLED

PLACE OVL VERTICAL SD ON BACKSIDE W/ # 1, 2, 3, ... ON THIS END

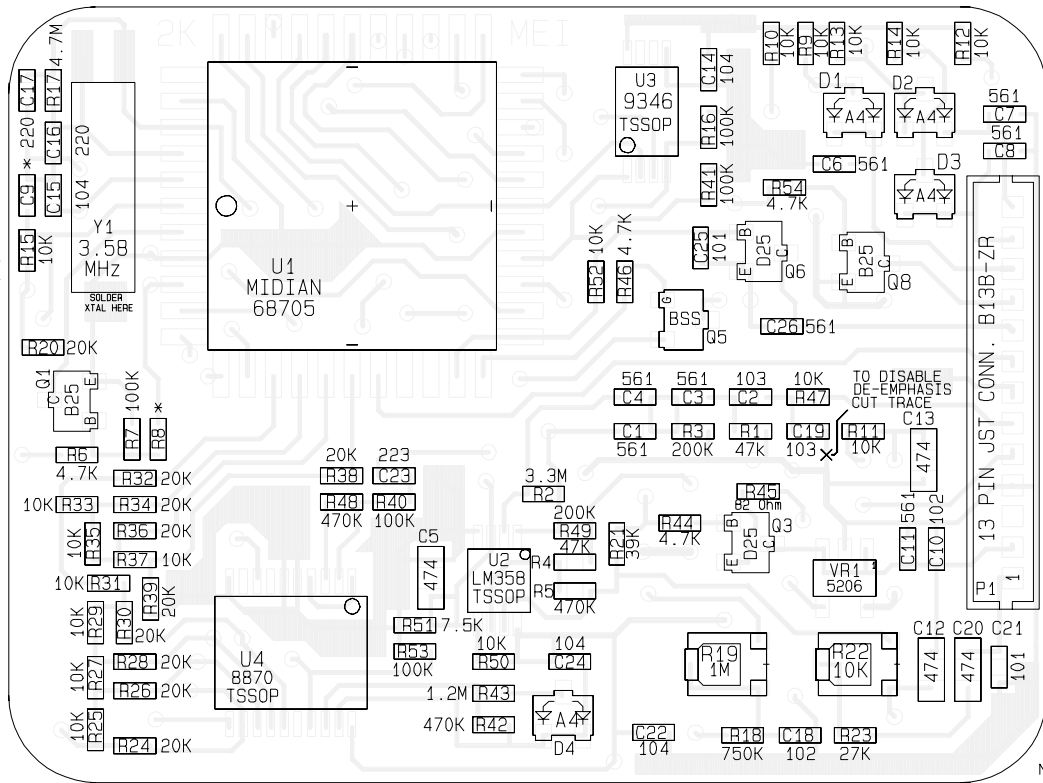

- OPTIONAL
- SECONDARY RX INHIBIT (VIO)
- ID SELECT/ PROG IN (ORG/W)
- PRIMARY RX DCS/CTCS IN (GRAY)
- PL INHIBIT LINE (GRY/W)
- PTT OUT (WHT)
- PROG_ENABLE (GRN/W)
- N/C (YEL)
- RX AUDIO IN (ORG)
- PROG BEEP (BLU)
- GND (BLK)
- PRIMARY RX COR/BUSY (BRN)
- VIN +5.5V-15 (RED)
- TX TONE/AUDIO OUT (GRN)

TO PREVENT SHORTING CUT CONNECTOR LEADS FLUSH BEFORE ADDING KAPTON TAPE STRIP TO CONNECTOR AREA

NOTE: * NOT INSTALLED

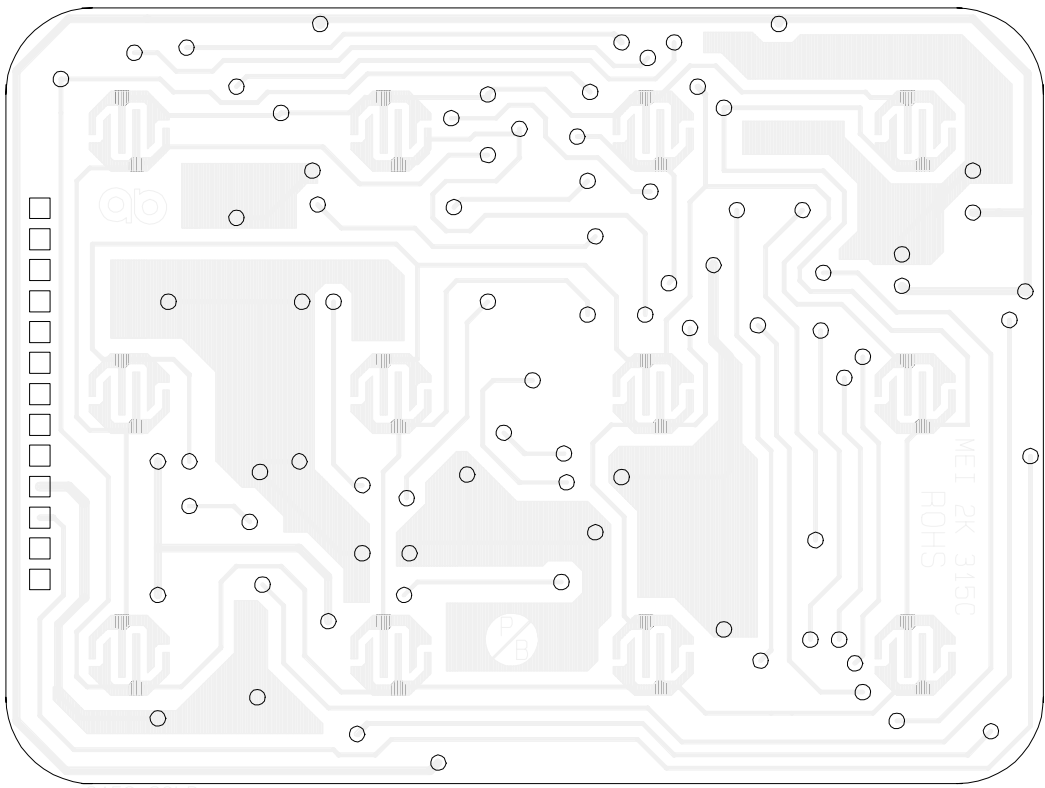

MIDIAN ELECTRONICS						REV.	FILE NO.
DATE	JAN 2K	DWN.BY	AB			APPR.	C
DESIGN	CJS	REV.	OCT 23/06	AB	PICTORIAL	SHEET	DWG. NO.
					COPYRIGHT © 2006		315-HCP