



RT-2

2-Tone Decoder

Manual Revision: 2010-05-04

Covers Software Revisions:

RT-2: 1.3 and higher

Covers Hardware Revisions:

UED-1: 283C

SPECIFICATIONS

Operating Voltage	+5.5-15 VDC
Operating Current	3 mA
Operating Temperature	-30 - +60 C
PTT Output Current	200 mA
Horn Output Current	200 mA
Disable Output	200 mA
Input Level	25-500 mV RMS
Input Impedance	100 K Ω
Audio Output Level	1V RMS
Audio Output Impedance	10K Ω /22 K Ω

GENERAL INFORMATION

The RT-2 is a 2-Tone decoder module that is capable of decoding up to 3 different 2-Tone sequences. The RT-2 offers momentary and latched outputs and supports individual and long tone group calls from 275 to 3500 Hz.

KL-3 PROGRAMMING

Midian's RT-2 is programmed using the KL-3 or a 12-button row/column keypad. For keypad programming see the Keypad Programming section below. Please reference the KL-3 manual for setup instructions of the KL-3 software and hardware. From the product selection screen on the KL-3 software, select the appropriate product name from the list and click OK.

Set the parameters of the product to fit the application. If any clarifications on a feature are required, move the mouse cursor over the feature name until the question mark appears and right click, a definition of the feature will be shown.

After entering the parameters, save the file by going to File - Save As. Enter the file name in the File Name block and click Save. Saving the file will allow for quick and easy reprogramming of units.

Connect the Orange/White wire to the Green KL-3 lead and the Black wire to a common ground with the KL-3's Black lead. The Yellow clip lead is not used with these products, as the RT-2 is non-readable.

Ground the PTT Input (Gray Wire); turn on power, and within 5 seconds click "Program Unit" in the menu bar to send the file to the product.

KEYPAD PROGRAMMING

If the RT-2 will be programmed with a 12-button row/column type keypad such as Midian's Keypad Option C, the RT-2 and the keypad should be oriented as shown below.

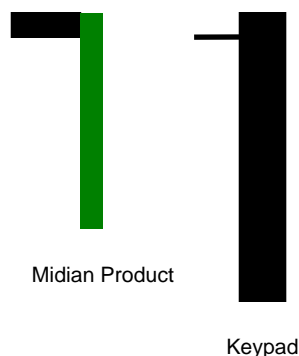

There are 7 pins on the keypad and 8 pin holes on the Midian product. Pins 1-7 are used on the Midian product. Pin 8 is only used if using a Row/Column Ground type keypad. The following diagram shows the pin numbers:

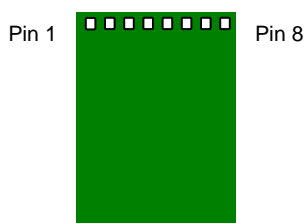

With the red, black and blue wires of the RT-2 connected, the keypad programming process may be done.

To enter programming mode on the RT-2 enter **27182818284** on the keypad.

The unit will beep 3 times to confirm entry into programming mode.

If during entry of a register's parameters a mistake is made, before *n is pressed, entering the # key will clear the register, so the register may be programmed properly. The programming register page at back of this manual can assist with the keypad programming of the RT-2.

To program a register (registers 1-3), enter the desired information plus *n, where n equals the register number. For example, 0349005105*1 would mean that 349.0 is the A tone and 510.5 is the B tone in the first decode address followed by the standard ring code of 1. If the register is successfully programmed the unit will beep 2 times. If during entry of the register's parameters a mistake is made, before *nn is pressed, entering the # key will clear the register, so the register may be programmed properly.

To program a register (registers 7-9), enter the desired information plus *n, where n equals the register number. If all entries in a register are not completed, trailing zeros will be automatically entered. Extra digits will be ignored. If the register is successfully programmed the unit will beep 2 times.

REGISTERS: Registers 1, 2, & 3

These fields set the tone sequence the RT-2 will decode. These fields are 11 digits in length. The first 5 are for frequency A, 0250.0 – 3500.0 Hz. The second 5 are for frequency B, 0250.0 – 3500.0 Hz. If both the A tone and the B tone are set for the same frequency, an additional 3.5 seconds will be added to the tone decode time programmed in register 8. This allows for group call decoding of a single long tone used in some systems.

The final digit is for the ring code. Select from the following options:

0 – This will activate the latched monitor/squelch output, but produce no ringing tones. The momentary horn output is disabled with this ring code.

1 – This will activate the latched and momentary outputs and produce a telephone like ring.

2 – This will activate the latched and momentary outputs and produce a pulsing ring tone.

4 – This will latch the horn output on until either the power is cycled or another sequence is decoded with a ring code of 5. When using the horn output in a latched state the Monitor/Squelch Output is disabled.

5 – This will unlatch the horn output. When using the horn output in a latched state the Monitor/Squelch Output is disabled.

8 – Turn off call lamp/mute. This resets the latched Monitor/Squelch Output.

9 – This will provide a latching output through Q7 that can only be reset by receiving the same sequence with this ring code.

Register 7A – Set this register for either a 0 for Ground or a 1 for V+. This sets the Monitor Input Active Polarity.

Register 7B – Set this register for 00.

Register 7C – Set this register for .0-.9 seconds. This sets the length of time the transmitter will key-up for.

Register 7D – Set this register for 00.

Register 7E – Set this register for 0.

Register 8A – Set this register for .01-.99 seconds. This sets the decode time for the first tone in a decode sequence. This time will also be applied to the second tone. The decode tone times should be set to approximately 1/5 of the shortest encode time. Example: Motorola Quick Call 2 would be .20 for a 1 sec 3 sec timing (20=200 ms).

Register 8B – Set this register for 00-99 seconds. This sets the length of time the unit rings when it decodes.

Register 8C – Set this register for 0-7. This sets the mode or tone the RT-2 will transpond in.

Register 8D – Set this register for 0-9 seconds. This field sets the time the momentary output will go to ground, before going high again.

Register 8E – Set this field to 0 for ground or 1 for V+. This must match the squelch polarity of the radio, when the radio is active. Squelch is controlled by the monitor input only.

Register 9A – Set this field to 00.

Register 9B – Set this field to 0.

Register 9C – Set this register to 0 for horn timeout in seconds and 1 for horn timeout in minutes. The horn timeout is programmable for 0-9 in either 1 second or 1 minute increments depending on how this register is programmed.

Register 9D – Set this field to 0.

Register 9E – Set this field to 0.

If all entries in a register are not completed, trailing zeros will be automatically entered. Extra digits will be ignored. If the register is successfully programmed the unit will beep 2 times.

If a register is not being used enter #*n. The “#” key acts as a clear command.

To exit programming mode type the following sequence:

***0**

Upon exiting the programming mode the unit will give a long beep and resume normal operation.

HARDWARE INSTALLATION

Be certain to follow standard anti-static procedures when handling any of Midian's products.

P1-4 – Black – Ground – Connect to the nearest ground point.

P1-2 – Red – +5.5 – 15 VDC – Connect to switched B+ in the radio.

P1-3 – Brown – COR/COS – Not used.

P1-6 – Orange – RX Tone Input – Connect to an audio point in the receiver, usually the high side of the volume control or discriminator output. When using CTCSS, pick up the audio after the high pass filter.

P1-7 – Yellow – Monitor/Squelch Output – Connect to a point in the squelch circuit that normally changes logic level with carrier. The squelch polarity is set in the KL-3 software and by selecting the polarity of D-5 by inserting either JU5 or JU6. R-47 can be changed to provide more or less current as needed. Do not allow the Monitor/Squelch Output to conflict with the COR/COS lead input.

P1-10 – Gray/White – Horn Output - This provides a 1-9 second/minute open-collector output to ground during ringing through Q8.

Disable – This feature is the Deadbeat Disable function. When activated Q7 latches low until commanded to unlatch. To access this feature, JU8 must be removed and JU7 installed.

P1-1 – Green – TX Tone Out – Connect to the modulator circuit. Use high impedance point in the radio. If generating CTCSS, use the CTCSS point in the modulator. Only needed if using the transpond tone.

P1-8 – Green/White – Mic Mute – Not typically used on this product.

P1-5 – Blue – Alert Tone/Speaker Audio – Connect to high side of the speaker. This provides Time-Out Timer, Penalty, and Go Ahead tones. When using 20-40 Ohm speakers, the onboard resistor in series with Q3 should be sufficient. When attaching this lead to a 4-8 Ohm speaker, add a 100-Ohm resistor in series with the lead to limit current.

P1-11 – Gray – PTT In – Not typically used on this product.

P1-9 – White – PTT Out – Connect to the PTT Switch of the radio. The PTT transistor, Q6, is rated at 100 mA continuous. This is only needed if using the transpond tone.

P1-12 – Orange/White – Monitor/Program In – For Program In, this lead is connected to the Green lead from the KL-3 programmer. For Monitor, this input can be used to reset the Monitor/Squelch Output.

P1-13 – Violet – Auxiliary/Emergency Input – Not used on this product.

HARDWARE ALIGNMENT

RX Audio Input: On the RT-2 adjust R65 so that Pin 14 of U2 (TP1) doesn't quite clip when a 1 KHz tone modulated at 3.3 KHz deviation from a signal generator is applied. Additionally, monitor TP2 (U2 Pin 8) for a clean symmetrical square wave. If more level is needed remove R63 by cutting JU1.

TX Audio Output: In a wide band system, set the modulation pot R22 to 3.3 KHz (66% of 5 KHz) of deviation per EIA specifications. In a narrow band system, set the modulation pot R22 to 1.65 KHz (66% of 2.5 KHz) of deviation per EIA specifications. Set CTCSS deviation to 750 Hz – 1 kHz. In Low-Z mic circuits, it may be necessary to short R23 and/or increase C20.

RADIO PROGRAMMING

The RT-2 is a generic module that wires into most radios. Any radio specific programming, if available, would be found on any Application Notes available for those radios. You may visit our website or call us for application notes.

OPERATION

Decode: Upon decode the unit will ring, via the Alert Tone/Speaker Audio line, according to the ring code programmed. The unit will also give the following outputs depending on the hardware configuration:

1. **Momentary Horn Output:** This will give an open collector output to ground for 1-9 seconds/minutes depending on the programmed horn time.
2. **Latched Monitor/Squelch Output:** This output can either go from low to high or from high to low. With JU-5 installed and the squelch polarity programmed for V+ the output will go from high to low. With JU-6 installed and the squelch polarity programmed for Ground the output will go from low to high.
3. **Disable Output:** If used, the Horn Output is not available. It will be necessary to reconfigure the hardware jumpers from the Horn to the Disable line. To use this output it is necessary to program the ring code as "Unit deadbeat disable". Upon receiving the decode sequence the output will latch and stay latched until it receives the sequence again.

Resetting of Outputs: The momentary output will automatically reset after 1-9 seconds/minutes depending on how the unit is programmed. The Monitor/Squelch output can be reset by cycling power, sending another sequence with the ring code of "Turn off call lamp/mute" or by grounding the monitor input. These reset options depend upon the programming of the unit.

Transpond: If programmed under the Transpond Mode field, the unit will key the PTT Output generate a tone or tone sequence via the TX Tone Out wire. Transpond only works on Decode Register 1.

TECHNICAL NOTES

Decode Timings: We recommend using the following timings:

2-tone: 200 msec for 1 second/3 second timing

MIDIAN CONTACT INFORMATION

Midian Electronics, Inc.

2302 East 22nd Street
Tucson, Arizona 85713 USA

Orders: 1-800-MIDIANS (643-4267)

Phone: 520-884-7981

Fax: 520-884-0422

E-mail: sales@midians.com

Web: www.midians.com

RT-2 PROGRAMMING WORKSHEET ver. 1.3 & higher

To access keypad programming enter: 27182818284

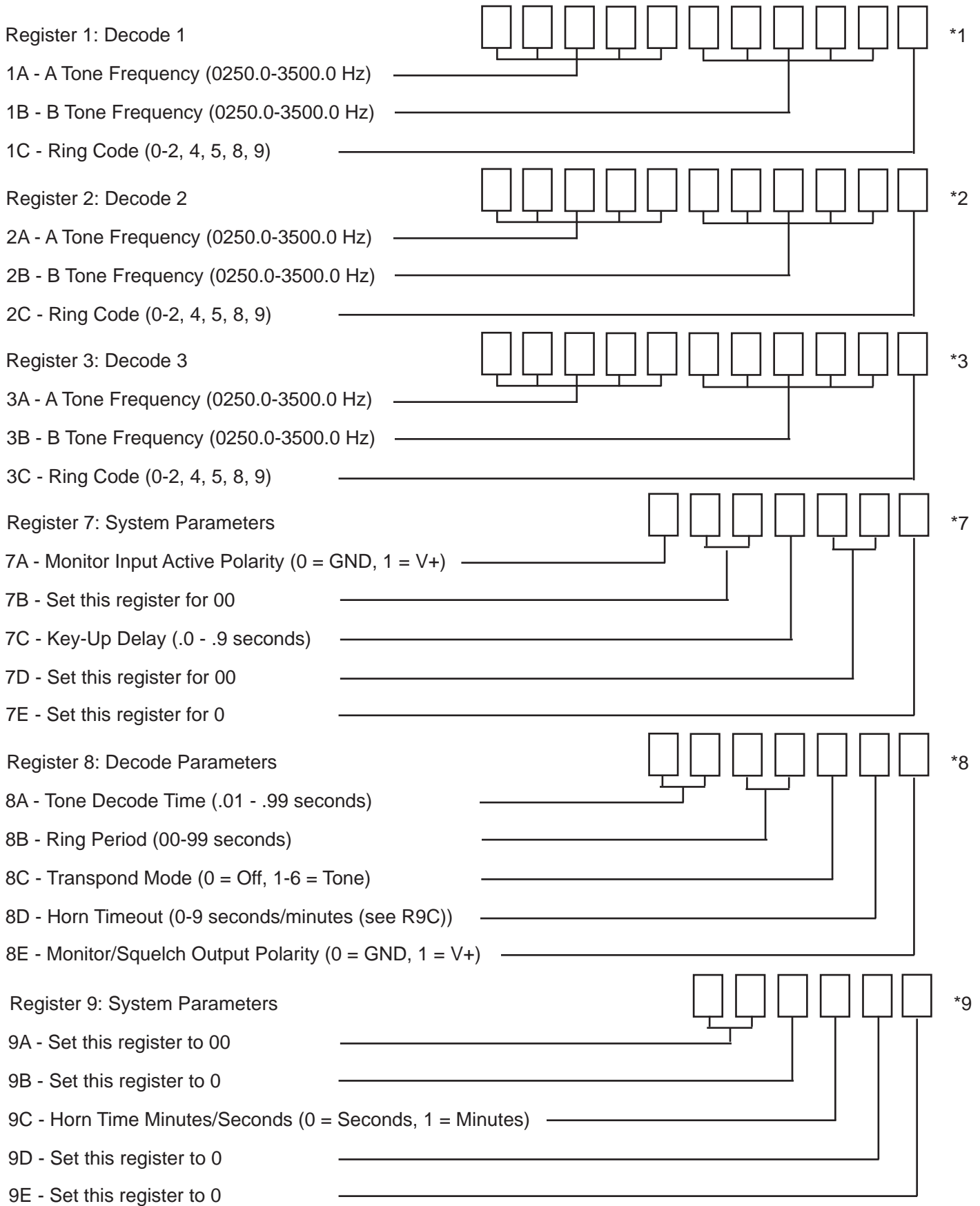

- This page intentionally left blank -

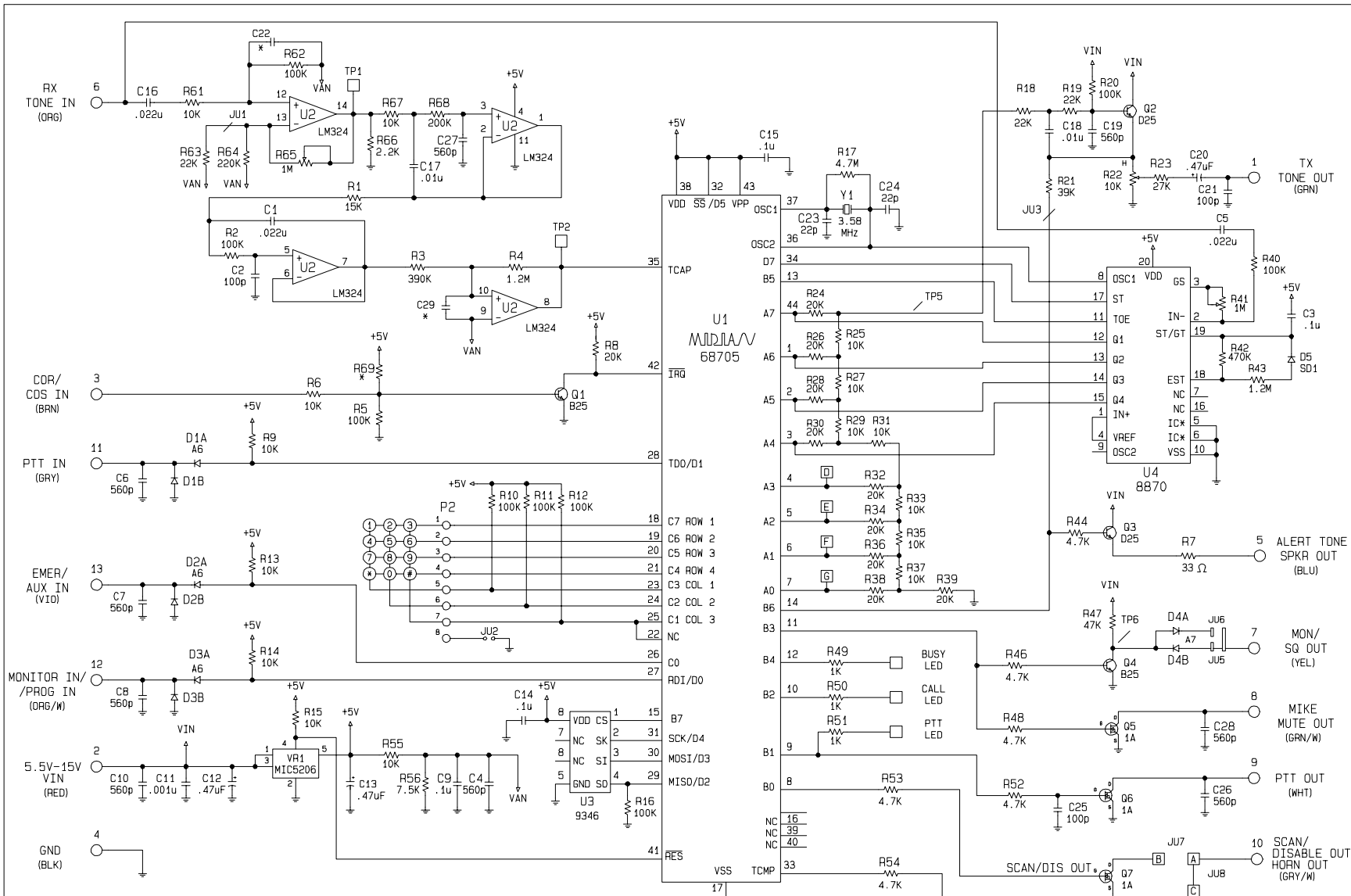

MIDIA ELECTRONICS			
DATE 02/14/97	DWN. BY AIB	APPR.	
DESIGN CJS	REV. OCT 31/06 AB		

UD-1B/UE-1B	REV. B	FILE NO. 283B.SCH
SCHEMATIC	SHEET	DWG. NO. 283B-HCD
COPYRIGHT © 2006		

NOTES:
 * NOT INSTALLED
 TO USE JU1, REMOVE R63
 TO USE JU3, REMOVE R21
 R1 - R69 C1 - C29
 D1-D5
 SKIP R45, 57, 58, 59, 60

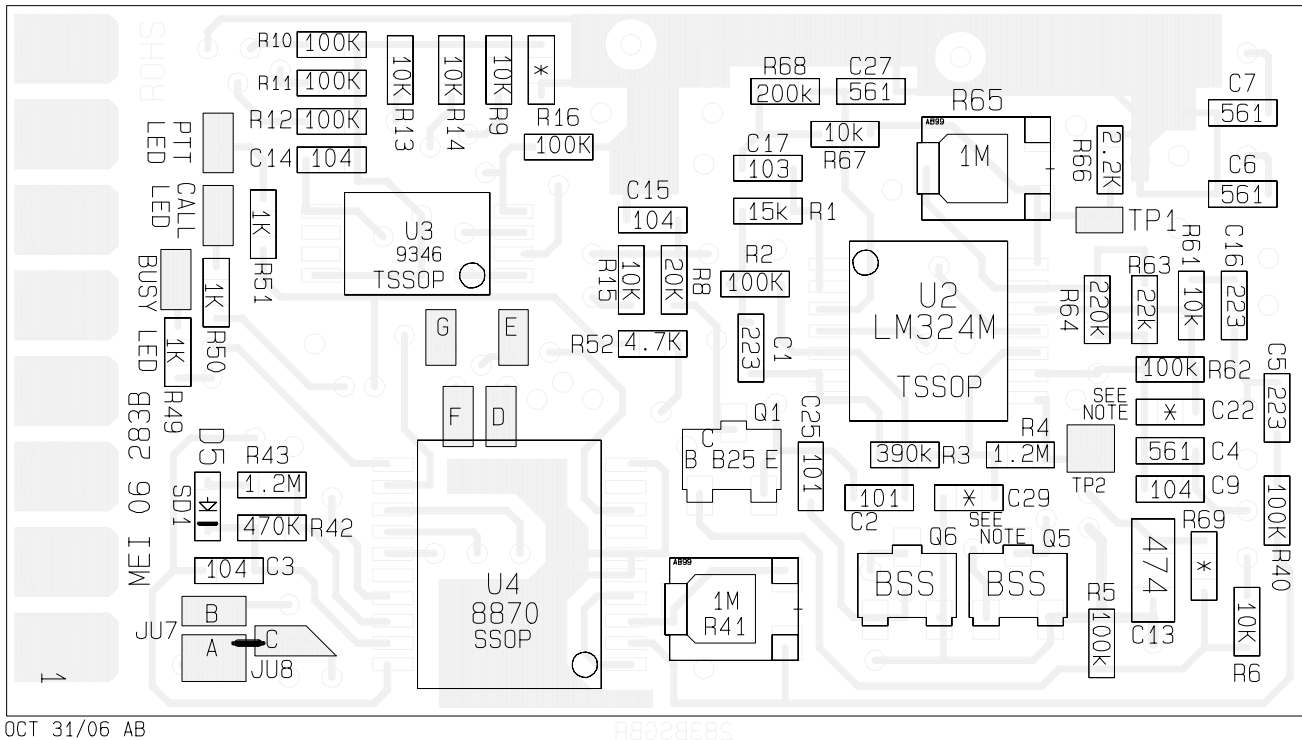
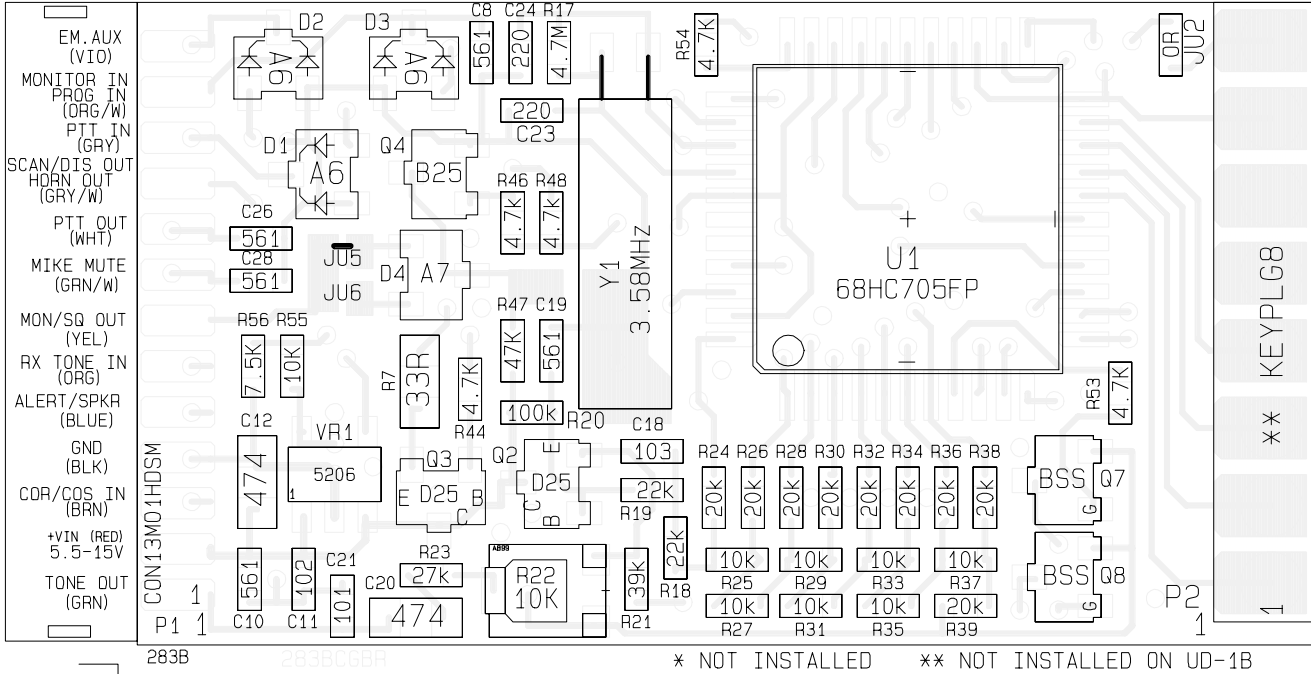

OCT 31/06 AB

MIDIAN ELECTRONICS			
DATE JULY 06	DWN.BY AB	APPR.	
DESIGN CJS	REV. OCT 31/06 AB		

UD-1B/UED-1B		REV. B	FILE NO. 283B.SCH
PICTORIAL		SHEET	DWG. NO. 283B-HCD
COPYRIGHT © 2006			