



TVS-2 HANDSET

High Level, Tactical Rolling Code Scrambler for Military Handsets

Manual Revision: 04-06-08

Covers Software Revisions:

TVS-2 HANDSET: 4.6

SPECIFICATIONS

Operating Voltage	5.5-15 VDC
Operating Current	9 mA
Input Level (RX)	0.3-4.0 V p-p adjustable
Input Impedance (RX)	1K Ω (typ)
Device Gain or Loss (RX/TX)	Unity
Frequency Response	300-2600 Hz
Carrier Suppression	60 dB <Peak Voice
Audio Output Impedance (TX)	1K Ω (min)
PTT Output Current	200 mA (max)
Synchronization Burst	90 msec
Synchronization Burst with ANI	140 msec
Operating Temperature	-30 - +60 C
Dimension:	Standard Military Handset
Encryption Sequences	1 Trillion
Random Number Generator	64 bits
Sequence Length (est.)	84 billion years
Hop Rate (standard)	Random 6-13 times/sec
Hop Rate (double)	Random 13-25 times/sec

INSTALLATION OVERVIEW

1. Test the radio for functionality.
2. Install the scrambler into the radio per the Hardware Installation Section of this manual.
3. Program the scrambler per the Product Programming Section of this manual.

***Midian is not responsible for any damage/loss resulting from the use of Midian's products.

ABOUT THE TVS-2 HANDSET

The TVS-2 HANDSET is a high-level rolling code scrambler that uses hopping type rolling code

encryption for higher security rather than sweeping code type. The scrambler is capable of features such as ANI, ENI, Deadbeat Disable, Spy, and more when using Midian's Kryptic Signaling format with the CAD-300 or DDU-300.

HARDWARE INSTALLATION

Be certain to follow standard anti-static procedures when handling any of Midian's products.

Installation Hints:

This product is designed to work on a PRC-77 type military radio using a 5-pin type military connector. Normally this radio does not hook up one of the pins to the power switch. In radios that do not use this pin, it will be necessary to install a short red jumper wire on the inside of the radio from the connector to the power switch. The PTT Out from the handset to the radio uses a Darlington transistor to key the radio and can handle 200 mA continuous. There is also a ground wire, mic wire, and earpiece receive audio lead. These are normally wired to the connector already.

THEORY OF OPERATION

How to use your high-security, tactical level scrambler handset

The TVS-2 scrambler is installed inside a commercial, waterproof military handset. It simply plugs onto a PRC-77 type military manpack radio. Other types of radios can be used but it is important to make sure that the connector pin configuration is the same.

Operation is quite simple.

To transmit in clear mode simply turn the power on and you will hear 2 beeps to indicate that you are in the clear mode. Use the handset as usual.

To transmit in scramble mode hold the Push to Talk button down while turning on the power to the radio. You will hear 4 ascending tones indicating that you are in the secure mode. When calling another user his handset will detect synchronization and if he is not in the secure mode, he will automatically switch to it and descramble the incoming message. He will remain in scramble mode so that he can talk back and carry on a secure conversation.

The unit that has been called is now in secure mode and if he wishes to return to clear mode, simply turn

the power off and then back on (2 beeps will be heard to indicate clear mode).

If a unit is in scramble mode already, and a clear call is transmitted from another **scrambled** handset, the unit will drop back to clear mode automatically.

If a unit is in scramble mode already, and a clear call is transmitted from a **non-scrambled** handset, the unit will remain in scramble mode and cannot understand the clear transmission from a regular, non-scrambled handset. In this case it would be necessary to flip the power off and then back on so that the **scrambled** handset comes up in the clear mode (indicated by 2 beeps).

For the safety of personnel and the security of voice communications we recommend keeping your TVS-2 Handset in the secure mode.

The scrambler in the handset receives audio from the earpiece wire from the manpack radio. It receives synchronization information, phone number decoding and scramble/clear audio via this wire. Therefore, the audio level cannot be turned down so low that nothing is presented to the earpiece wire. On the PRC-77 type radio, keep the volume control above the second dot on the volume control and below the ninth dot. Above the ninth dot, the radio tends to generate distortion and the audio presented to the ear becomes painful. The most comfortable level seems to be between the second and fourth dot.

This product works quite well in FM mode and AM mode. In single sideband the synchronization is not as reliable as in the other modes. Some users have good results with synchronization in the SSB modes while others claim they do not. But SSB regardless usually has a duckish quality to the voice audio and this same degraded audio quality affects synchronization. Using high stability oscillators in the SSB mode seems to improve this.

True Frequency Hopping Encryption

Unlike most competing rolling code inversion scramblers, Midian's TVS-2 series scramblers literally hop from one inversion frequency to another, providing superior security. Competing units while claiming to be hoppers are actually sweepers. This allows them to claim very high "hop" rates of say, 250 times per second or more, while actually providing less security.

Sweepers offer less security because the inversion frequency can be more easily tracked (using the proper equipment). Sweepers are more predictable because of the continuous nature of the sweep. Midian's TVS-2 series cannot be tracked in the same

manner because the inversion frequency, which encrypts the voice, changes by at least 25% for every hop. The direction, amount of frequency shift, and the dwell time for each hop is based on a 64-bit random number generator.

PRODUCT PROGRAMMING

Midian's TVS-2 HANDSET is programmed via Midian's KL-3 programming cable. Please reference the KL-3 manual (included on the CD-ROM labeled "Programming Software & Product Manual CD-ROM") for setup instructions of the KL-3 software and hardware. From the product selection screen on the KL-3 UP software, select the TVS-2-HANDSET from the list and click OK.

Set the parameters of the TVS-2 HANDSET software to fit the application. If any clarifications on a feature are required, move the mouse cursor over the feature name until the question mark appears and right click, a definition of the feature will be shown.

After entering the parameters, save the file by going to File - Save As. Enter the file name in the File Name block and click Save. Saving the file will allow for quick and easy reprogramming of units.

For programming, connect the KL-3's green Program clip lead to the Program In hole on the TVS-2 module located in the handset. Click on Program Unit in the KL-3 software to download the data to the TVS-2.

For reading, connect the KL-3's green Program clip lead to the Program In hole and the yellow Read clip lead to the Program Out hole on the TVS-2 module located in the handset. Click on Read Unit in the KL-3 software to read the data in the TVS-2.

MIDIAN CONTACT INFORMATION

Midian Electronics Inc.
2302 East 22nd Street
Tucson, Arizona 85713 USA

Orders: 1-800-MIDIANS
Phone: 520-884-7981
Fax: 520-884-0422
E-mail: sales@midians.com
Web: <http://www.midians.com/>

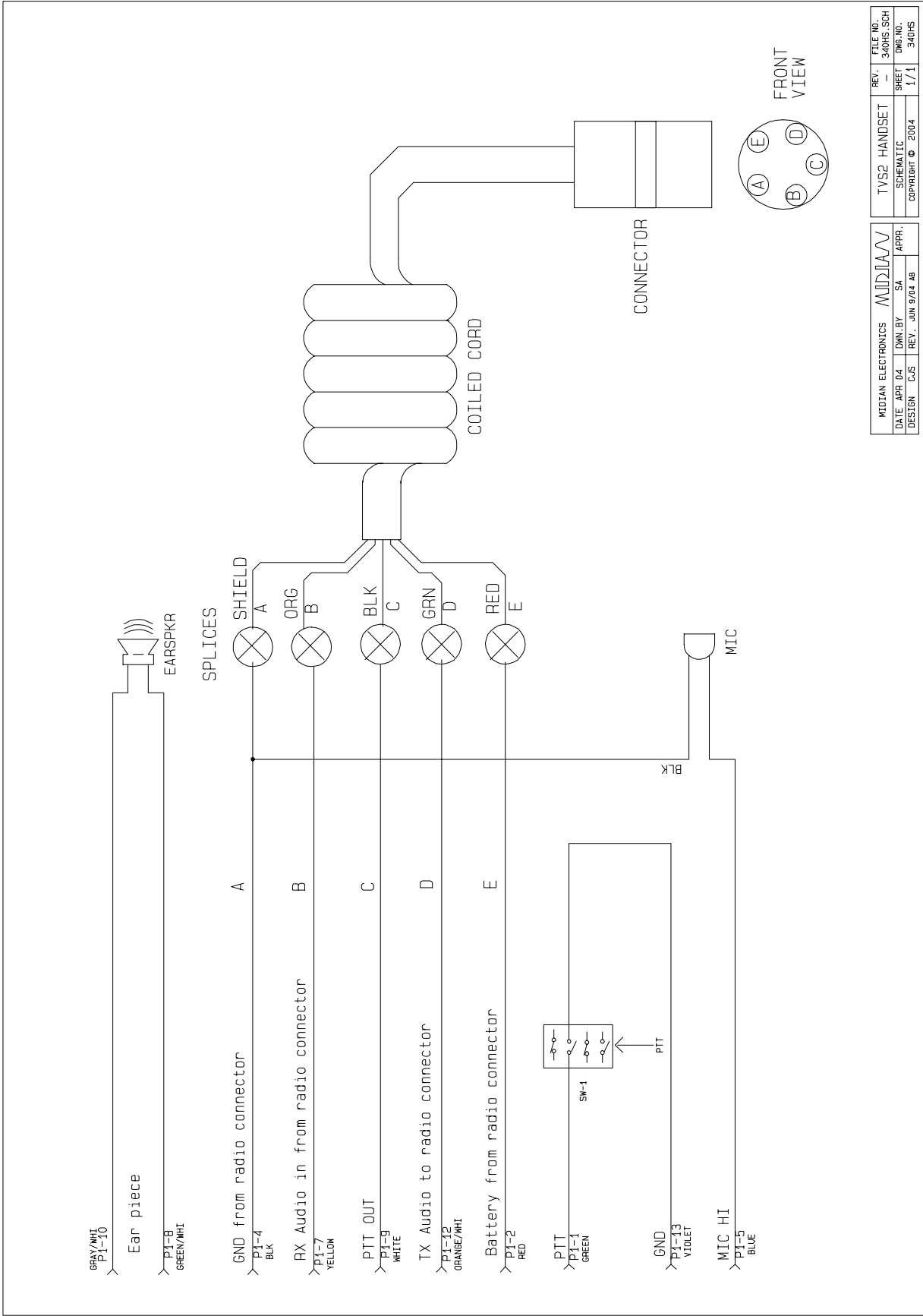

MIDIAN ELECTRONICS	MDIAN	REV.	FILE NO.
DATE APR 04	DNL BY SA	TVS2 HANDSET	340HS.SCH
DESIGN CJS	REV. JUN 9/04 AB	SCHEMATIC	340HS
		COPYRIGHT © 2004	1/1
			340HS

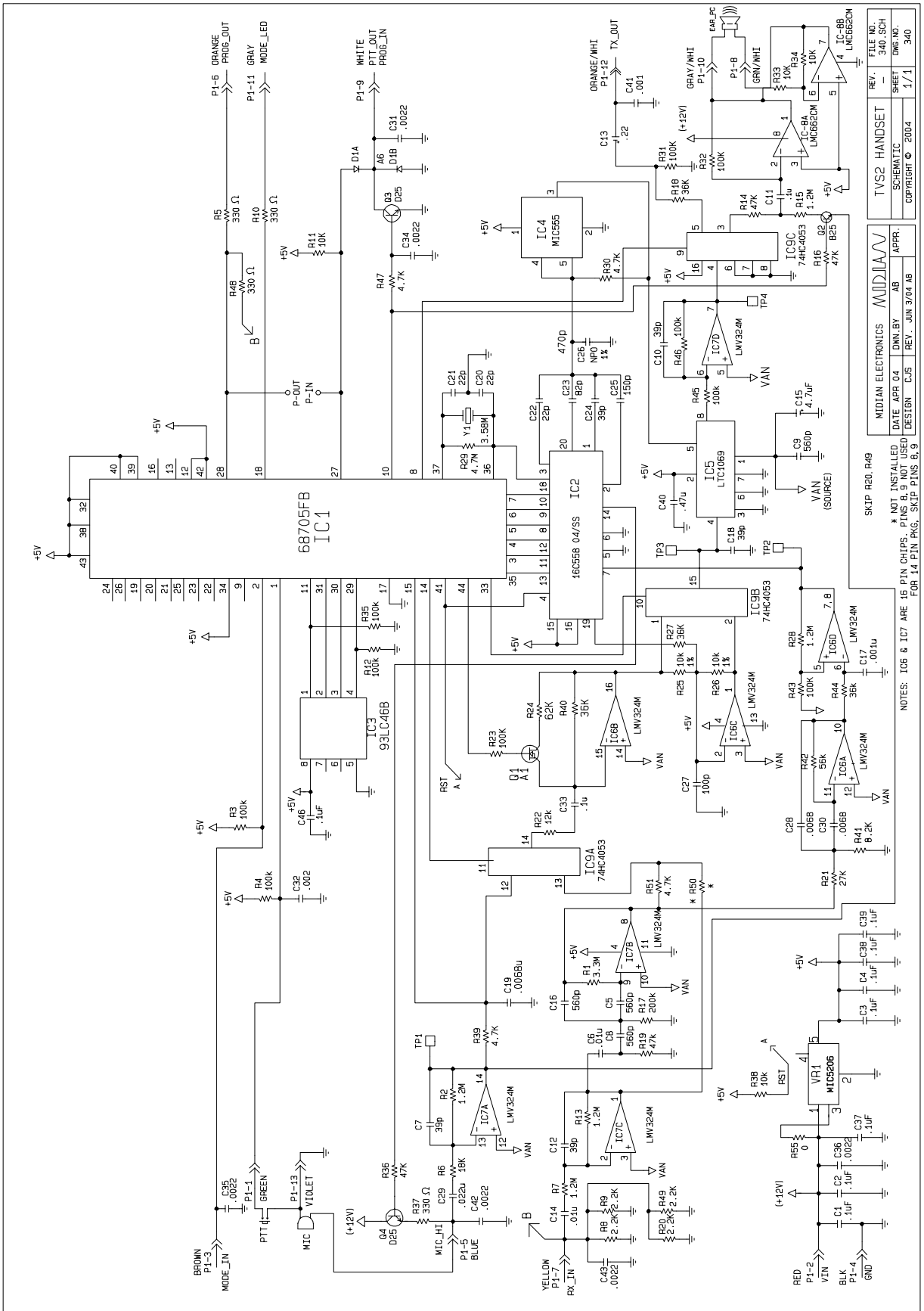

REV. 1/1
 SHEET 340
 DWG. NO. 340
 SCHEMATIC

FILE NO. 340
 MIDDIAN ELECTRONICS
 DATE APR 04
 DNN.BY AB
 APPR. JUN 3/04 AB

TVS2 HANDSET
 DESIGN CJS
 REV. JUN 3/04 AB
 COPY/RIGHT © 2004

SKIP R20, R49
 * NOT INSTALLED
 PINS 8, 9 NOT USED
 FOR 14 PIN Pkg. SKIP PINS 8, 9

NOTES: IC6 & IC7 ARE 15 PIN CHIPS.
 PINS 8, 9 NOT USED
 FOR 14 PIN Pkg. SKIP PINS 8, 9

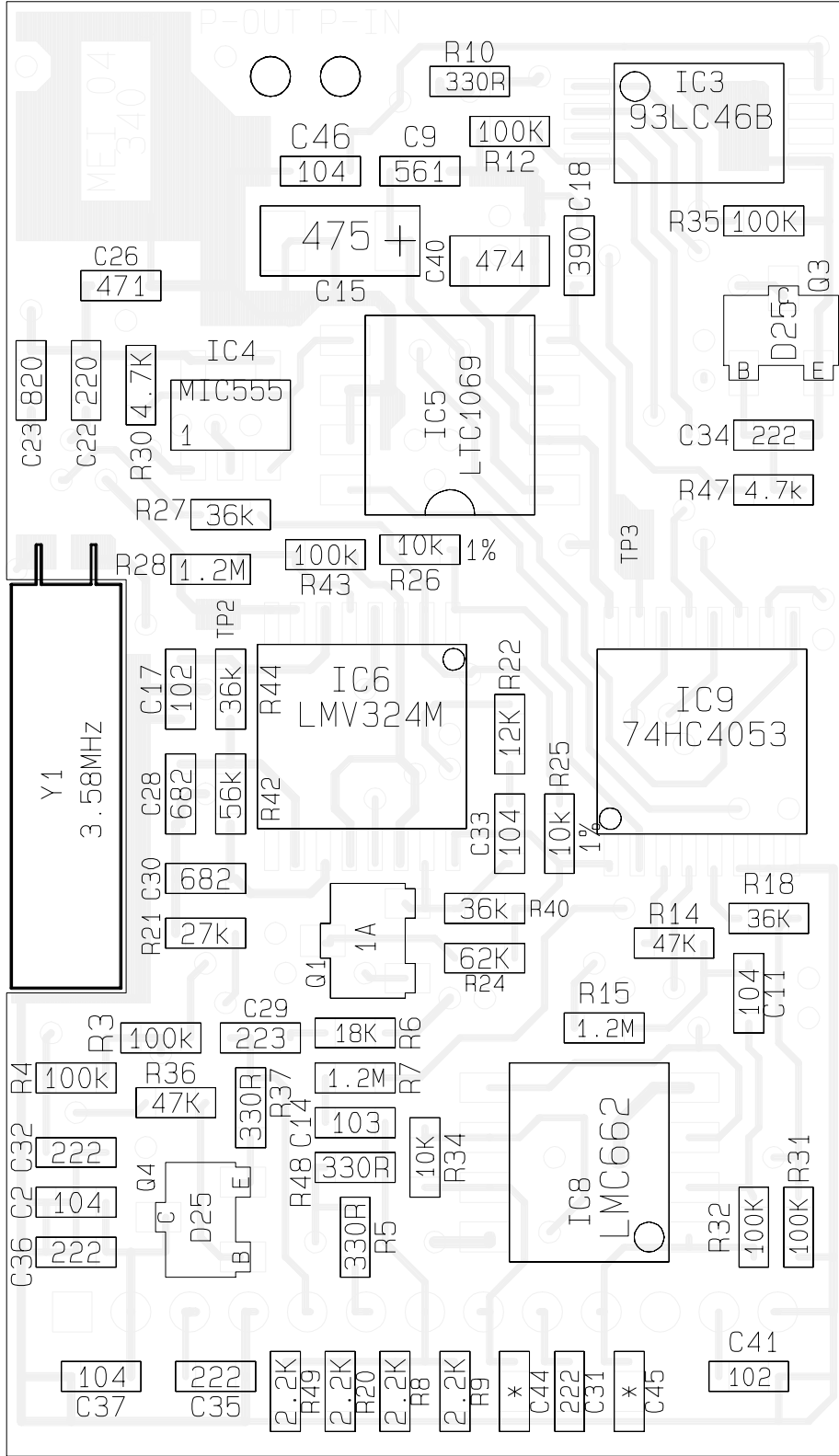

* NOT INSTALLED TVS2 HANDSET SOLDER

340.PCB

MIDIAN ELECTRONICS	MIDIAN	FILE NO.	340.PCB
DATE APR 2004	DNW.BY AB	REV.	-
DESIGN CJS	REV. JUN 8/04 AB	TVS2 HANDSET	SHEET
		PICTORIAL	340-CHP
		COPYRIGHT © 2004	