



## UED-1B & EED-1B Bezel Multi-Format Encoder/Decoder/Dialer

Manual Revision: 04-07-15

### Covers Software Revisions:

UED-1: 4.0

EED-1: 1.4

### SPECIFICATIONS

Operating Voltage	+5.5-15 VDC
Operating Current	3 mA
Operating Temperature	-30 - +60 C
PTT Output Current	200 mA
Horn Output Current	200 mA
Disable Output	200 mA
Input Level	25-500 mV RMS
Input Impedance	100 K $\Omega$
Audio Output Level	1V RMS
Audio Output Impedance	10K $\Omega$ /22 K $\Omega$

### ABOUT THE UED-1 SERIES

The UED-1 Series offers ANI encoding, dialing, decode and transpond of tone formats such as DTMF, 5-tone, 2-tone, Pulse Tone, and Burst Tone. The UED-1 Series can be used with Midian's CAD-100/200 or DDU-100/200 for dispatching in fleets or it can be used for equipment or alarm activations.

### PRODUCT PROGRAMMING

For programming via a keypad, please reference the UE/UED Series Keypad Programming Manual.

Midian's UED-1 & EED-1 Products are programmed using the KL-3 programmer. Please reference the KL-3 manual for setup instructions of the KL-3 software and hardware. From the product selection screen on the KL-3 UP software, select the appropriate product name from the list and click OK.

Set the parameters of the UED-1 or EED-1 to fit the application. If any clarifications on a feature are required, move the mouse cursor over the feature

name until the question mark appears and right click, a definition of the feature will be shown.

After entering the parameters, save the file by going to File - Save As. Enter the file name in the File Name block and click Save. Saving the file will allow for quick and easy reprogramming of units.

Connect the Orange/White wire to the Green KL-3 lead and the Black wire to a common ground with the KL-3's Black lead. The Yellow clip lead is not used with these products, as the UED-1 & EED-1 are non-readable.

Ground the PTT Input (Gray Wire); turn on power, and within 5 seconds click "Program Unit" in the menu bar to send the file to the UED-1 or EED-1.

### HARDWARE INSTALLATION

Be certain to follow standard anti-static procedures when handling any of Midian's products.

**Black** – Ground – Connect to the nearest ground point.

**Red** - +5.5 – 15 VDC – Connect to switched B+ in the radio.

**Brown** – COR/COS – Connect to point in the squelch or CTCSS circuit that changes logic level when carrier is received.

**Orange** – RX Tone Input – Connect to an audio point in the receiver, usually the high side of the volume control or discriminator output. When using CTCSS, pick up the audio after the high pass filter.

**Yellow** – Monitor/Squelch Out – Connect to a point in the squelch circuit that normally changes logic level with carrier. The squelch polarity is set in the KL-3 software and by selecting the polarity of D-5 by inserting either JU4 or JU5. R-47 can be changed to provide more or less current as needed. Do not allow the Monitor/Squelch Output to conflict with the COR/COS lead input.

**Gray/White** – Disable – This feature is the Deadbeat Disable function of the UED-1. When activated Q7 latches low until commanded to unlatch. This is the standard configuration from the factory.

**Horn Pad** – This provides a 0-9 second ground during ringing through Q8. This is primarily used in alarm type applications to ring sirens, activate lights or equipment through the use of a relay.

**Green** – TX Tone Out – Connect to the modulator circuit. Use high impedance point in the radio. If generating CTCSS, use the CTCSS point in the modulator.

**Green/White** – Mic Mute – If desired, connect to mic element bias point or to some other point in the audio amp to crowbar mic audio to ground during ANI to prevent voice interference.

**Blue** – Alert Tone/Speaker Audio – Connect to high side of the speaker. This provides Time-Out Timer, Penalty, and Go Ahead tones. When using 20-40 Ohm speakers, the onboard resistor in series with Q3 should be sufficient. When attaching this lead to a 4-8 Ohm speaker, add a 100-Ohm resistor in series with the lead to limit current.

**Gray** – PTT In – Requires a logic low from the radio's PTT switch. If TOT is not needed, the PTT In & Out wires can be tied together and connected directly across the radio's PTT switch. For non-common PTT, open the PTT path and connect the gray wire to the switch.

**White** – PTT Out – Connect to the other side of the open PTT path as referred to in the above step. The UED now has control of the PTT for Time Out Timer (TOT) and penalty timer. The PTT transistor, Q6, is rated at 100 mA continuous.

**Orange/White** – Hook/Monitor/Program In – For Program In, this lead is connected to the Green lead from the KL-3 programmer.

**Violet** – Auxiliary/Emergency Input – When taken to Ground, this input can send Emergency or encode in a secondary dialing format. This depends on the Auxiliary Input setting in the KL-3 under the Control tab. This lead can also be used to disable the transpond.

## HARDWARE ALIGNMENT

**RX Audio Input:** On the UED-1B Bezel, adjust R41, so that Pin 1 of U2 TP1 doesn't quite clip when a 1 KHz tone modulated at 3.3 KHz deviation from a signal generator is applied.

For DTMF, adjust R41 so that Pin 3 of U4 TP4 has a voltage not exceeding 1.5 VPP.

**TX Audio Output:** In a wide band system, set the modulation pot R23 to 3.3 KHz (66% of 5 KHz) of deviation per EIA specifications. In a narrow band system, set the modulation pot R23 to 1.65 KHz (66% of 2.5 KHz) of deviation per EIA specifications. Set CTCSS deviation to 750 Hz – 1 kHz. In Low-Z

mic circuits, it may be necessary to short R23 and/or increase C20.

**COR/COS:** If the radio only makes a minute change, it may be necessary to adjust the R6 & R7 to cause Q1 to change states:

## RADIO PROGRAMMING

The UED-1 & EED-1 products are generic modules that wire into most radios. Any radio specific programming, if available, would be found on any Application Notes available for those radios. You may visit our website or call us for application notes.

## OPERATION

**ANI Encode:** When the PTT Input is grounded, the unit will assert the PTT Output and send the programmed ANI tones out the TX Tone Output.

**ENI Encode:** When the Emergency Input is grounded, the unit will assert the PTT Output and send the programmed Emergency ANI tones out the TX Tone Output.

**Keypad Dialing:** To send a page or make a selective call via the keypad enter the desired sequence followed by the \* key. The \* key acts as the send key. If a mistake is made during entry, press the # key to clear the entry. When the \* key is pressed the unit will assert the PTT Output and send the sequence out the TX Tone Output.

**Memory Dialing:** The technical notes section explains how to enter the memory dials into memory. To send a sequence from memory enter the \* key followed by a 0-9 that corresponds to the sequence in memory you wish to send. When the memory dial is entered the unit will assert the PTT Output and send the sequence out the TX Tone Output.

**Decode:** Upon decode the unit will ring, via the Alert Tone/Speaker Audio line, according to the ring code programmed. The unit will also give the following outputs depending on the hardware configuration:

1. Momentary Horn Output: This will give an open collector output to ground for 0-9 seconds depending on the programmed horn time.
2. Latched Monitor/Squelch Output: This output can either go from low to high or from high to low. With JU-4 installed and the squelch polarity programmed for V+ the output will go from high

to low. With JU-5 installed and the squelch polarity programmed for Ground the output will go from low to high.

3. Latched Mic Mute: This will give an open collector to ground. It will be necessary to install a 10 K $\Omega$  Ohm resistor to the open collector. Set the Monitor Polarity to Ground and the Input as "Controls Squelch". The Squelch Control should be "Unmute when called" or "Stay muted until called". The Monitor or Inactivity field can be programmed to any setting.
4. Latched Disable Output: If used, the Horn Output is not available. It will be necessary to reconfigure the hardware jumpers from the Horn to the Disable line. To use this output it is necessary to program the ring code as "Unit deadbeat disable". Upon receiving the decode sequence the output will latched and stay latched until it receives the sequence again.

**Resetting of Outputs:** The momentary output will automatically reset after 0-9 seconds depending on programming. The Mic Mute and Monitor/Squelch outputs can be reset by recycling power, sending another sequence with the ring code of "Turn off call lamp/mute", resetting on a loss of carrier, by grounding the monitor input, or after 25 seconds of inactivity. These reset options depend upon the programming of the unit.

**Transpond:** If programmed, upon decode the unit can transpond a tone sequence back to the caller to indicate the unit decoded. Transpond only occurs on Decode #1.

**COR Input:** This input controls two functions, busy lockout and reset of a loss of carrier. The COR polarity must be programmed for the active carrier polarity of the radio.

1. Busy Lockout: If COR is active and the unit tries to encode with busy lockout enabled, the unit will be prevented from keying up.
2. Reset on Loss of Carrier: The unit can reset the latched outputs after a loss of carrier of 0-9 seconds depending on programming.

## TECHNICAL NOTES

**Decode Timings:** We recommend using the following timings:

5-tone: 5 msec for 30-70 msec tones  
5-tone: 10 msec for 70-100 msec tones  
Pulse (1500 & 2805 Hz): 10 msec  
2-tone: 200 msec  
DTMF: 1 sec

**Memory Dial:** The UED-1 and EED-1 support a 10 number memory dial and last number redial. Last number redial is accomplished by entering \*\*. To enter the programming mode for memory dial enter the following sequence:

**000000**

The unit will beep 3 times to confirm entry into programming mode.

To enter a memory dial enter the sequence followed by \*n, where n equals the memory location (0-9). For example 1234\*1 would enter a sequence of 1234 in the first memory dial register. For special characters such as A, B, C and D press the PTT while pushing the "2" key for A, the "5" key for B, the "8" key for C, and the "0" key for D. The European group tone "G" can also be used by holding the PTT and pressing the "\*" key. To exit memory dial programming, enter the following sequence:

**000000**

The unit will respond with a long beep and resume normal operation.

To dial from memory, simply enter \*n, where n equals the memory location (0-9).

## MIDIAN CONTACT INFORMATION

Midian Electronics Inc.  
2302 East 22<sup>nd</sup> Street  
Tucson, Arizona 85713 USA

Toll-Free: 1-800-MIDIANS  
Phone: 520-884-7981  
Fax: 520-884-0422  
E-mail: [sales@midians.com](mailto:sales@midians.com)  
Web: <http://www.midians.com/>

*- This page intentionally left blank -*

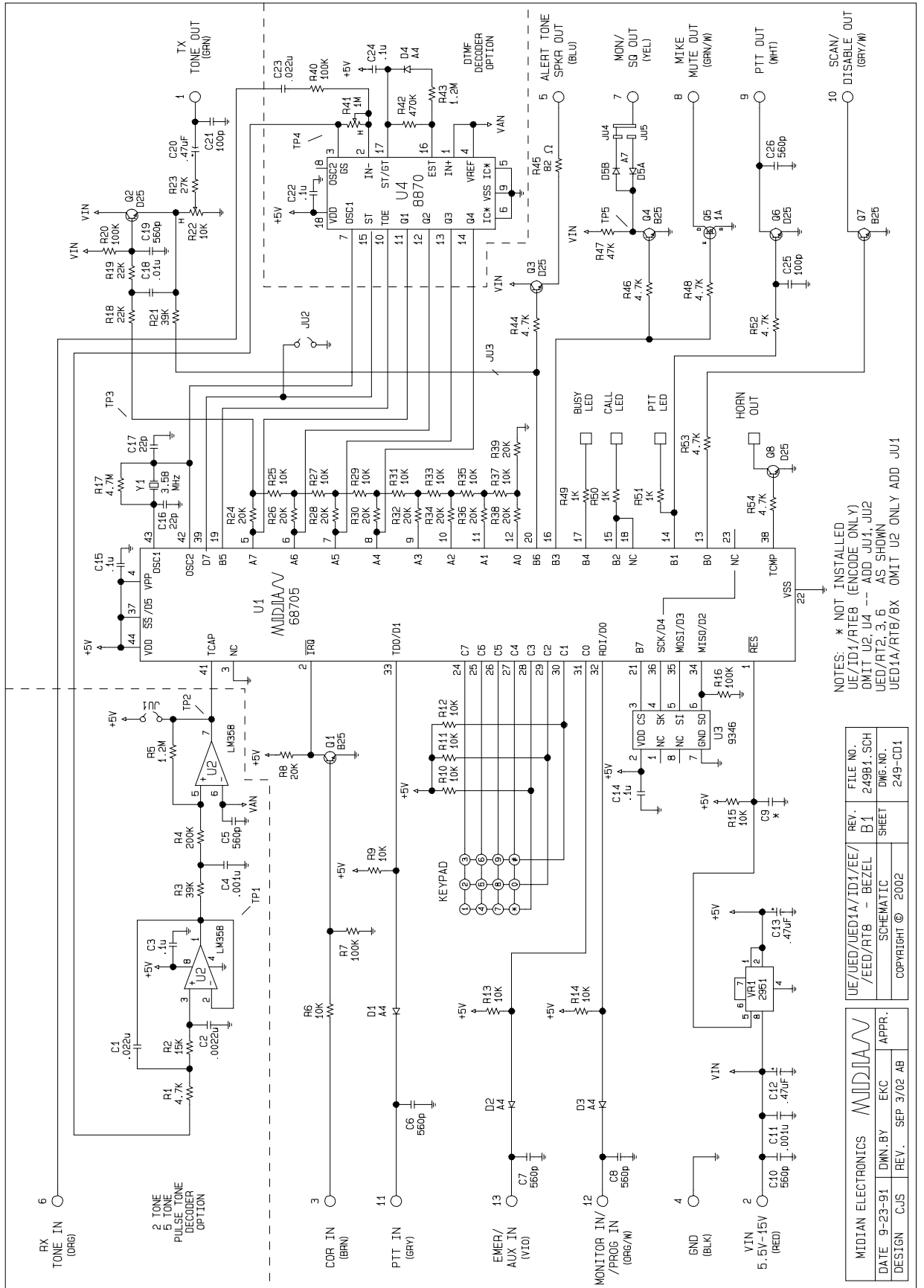

NOTES: \* NOT INSTALLED  
 UE/ID1/RT8 (ENCODE ONLY)  
 OMIT U2, U4 -- ADD JU1, JU2  
 UED/RT2, 3, 6 AS SHOWN  
 UED1A/RT8/BX OMIT U2 ONLY ADD JU1

UE/UED/RT8	REV. B1	FILE NO. 24981.SCH
/EED/RT8 - BEZEL	SHEET	DWG. NO.
SCHEMATIC	COPYRIGHT © 2002	249-CD1

MIDIAN ELECTRONICS	MIDIAN	APPR.
DATE 9-23-91	DMN.BY EKC	REV. 3/02 AB
DESIGN CJS	REV. SEP 3/02 AB	

*- This page intentionally left blank -*

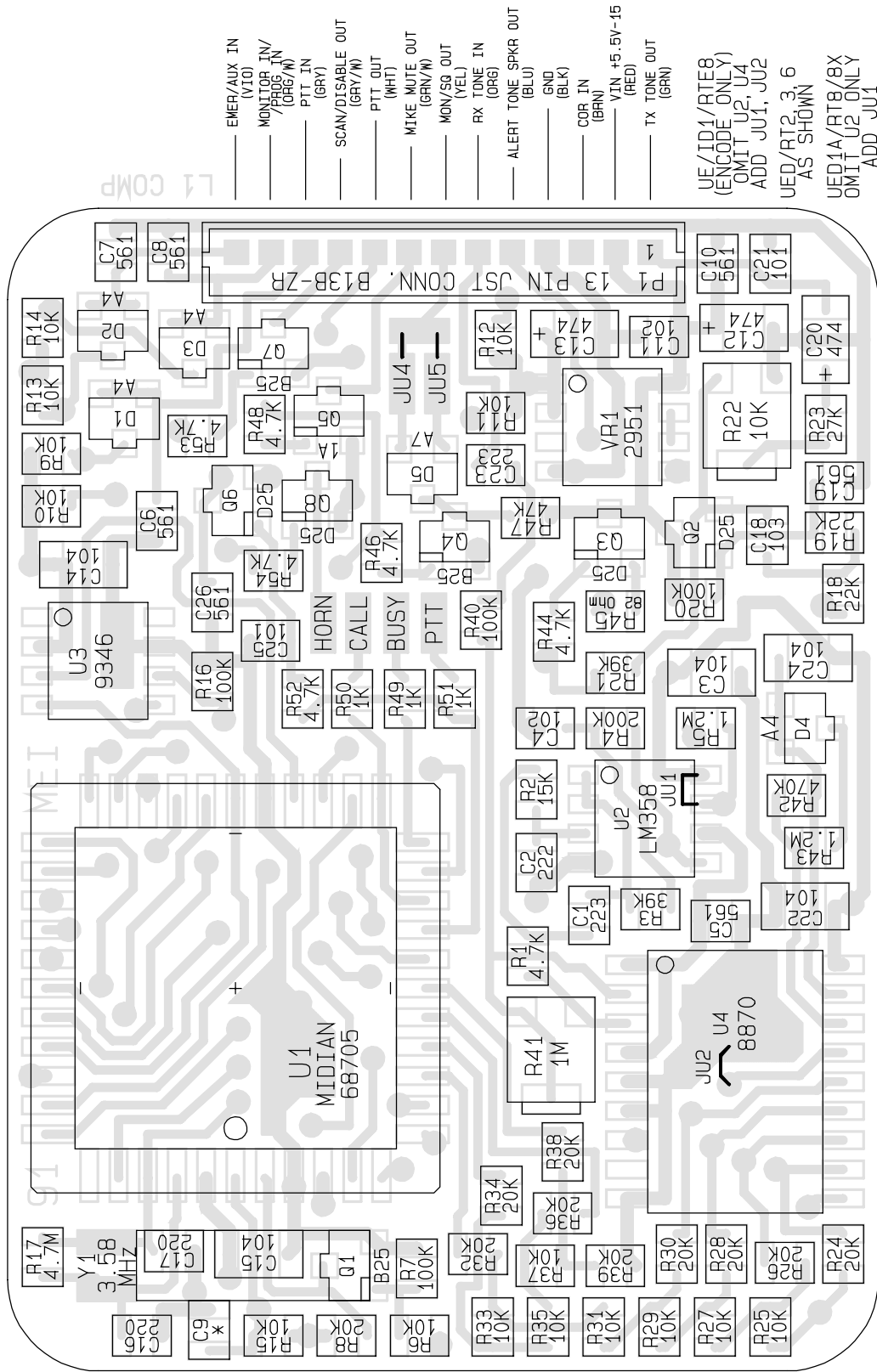

L1 COMP

- EMER/AUX IN (VIO)
- MONITOR IN / PROG IN (ORG/W)
- PTT IN (GRY)
- SCAN/DISABLE OUT (GRY/W)
- PTT OUT (WHT)
- MIKE MUTE OUT (GRN/W)
- MON/SG OUT (YEL)
- RX TONE IN (ORG)
- ALERT TONE SPKR OUT (BLU)
- GND (BLK)
- COR IN (BRN)
- VIN +5.5V-15 (RED)
- TX TONE OUT (GRN)

UE/ID1/RTE8 (ENCODE ONLY)  
 OMIT JU2, U4  
 ADD JU1, JU2  
 UED/RT2, 3, 6 AS SHOWN  
 UED1A/RT8/BX OMIT JU2 ONLY  
 ADD JU1

MIDIAN ELECTRONICS	MIDIAN	UE/UED/IED1A/ID1/EE EED/RT8 -BEZEL PICTORIAL	REV. B SHEET	FILE NO. 129B1.PCB
DATE 9-30-91	DNW.BY EKC	APPR.	COPYRIGHT © 2002	DMG.NO. 249-HCP
DESIGN CJS	REV. SEP 3/02 AB			

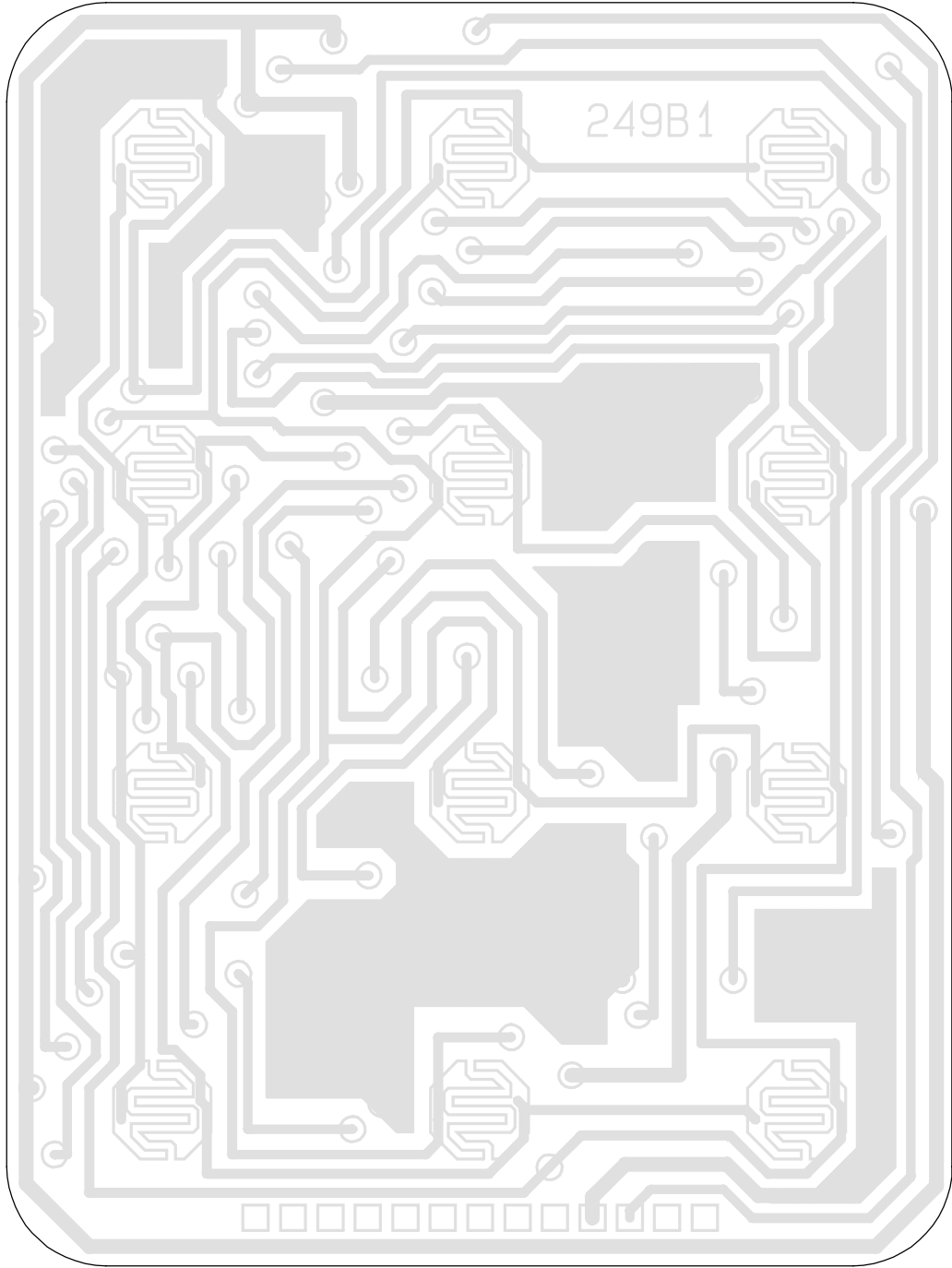

MIDIAN ELECTRONICS		MIDIAN		UE/UEJ/UEJ1A/ID1/EE		REV.		FILE NO.	
DATE 9-30-91	DESIGN CJS	OWN. BY EKC	REV. SEP 3/02 AB	-BEZEL	PICTORIAL	SHEET	B	129B1.PCB	
				COPYRIGHT © 2002				DMG. NO.	
								249-HCP	