



VPU-12-TAIT

Voice Inversion Scrambler for the Tait Radios

Manual Revision: 05-09-01

Covers Software Revisions:
VPU-12-TAIT: 1.4

This manual & product supports the following radios:
Tait Orca 5010/5020/5040
Tait T-2020/203X/2040

SPECIFICATIONS

| | |
|---------------------------------|--------------|
| Operating Voltage | 5 VDC |
| Operating Current | 5.5 mA |
| Operating Temperature | -30 - +60 C |
| Frequency Response | 300-2200 Hz |
| Device Gain or Loss | Unity |
| Carrier Suppression | -60 dB |
| Audio Output Impedance | <1K Ω |
| Inversion Frequency Range | 2200-4096 Hz |
| Number of Inversion Frequencies | 16 |

INSTALLATION OVERVIEW

1. Test the radio for functionality.
2. Program the radio per the Radio Programming Section of this manual.
3. Install the scrambler into the radio per the Hardware Installation Section of this manual.
4. Program the scrambler per the Product Programming Section of this manual.

***Midian is not responsible for any damage/loss resulting from the use of Midian's products.

ABOUT THE VPU-12-TAIT

The VPU-12-TAIT is a multi-code voice inversion scrambler that will protect communications against the casual listener.

RADIO PROGRAMMING

Tait Orca Series:

In the "Specifications" screen, set the "Maximum Number of Encryption Codes" to the desired number of codes (1-16 codes). This should correspond to the number of codes programmed into the VPU-12 scrambler. The 5010 can only be single code.

In the "Key Settings" screen, set the Function 1, 2 or 3 key for mode select and code select. It is recommended to program the Short Press key to "Encryption On/Off" for mode select and the Long Press key to "Encryption Code Select" for code select. If only using 1 security code it is not necessary to program a key for code select.

Tait T-2000 Series:

In the "Key Settings" window, set the "Key Operation" as latching.

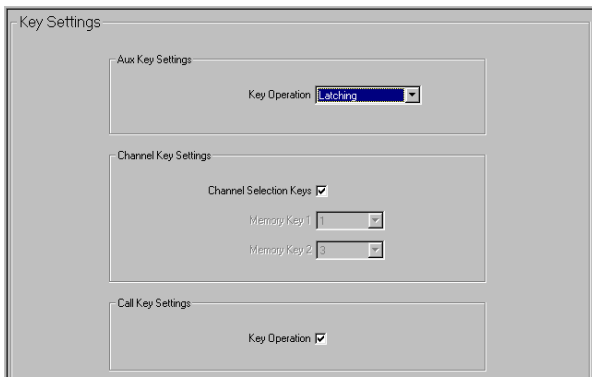

In the “Specifications” window, check the “Scrambler” box under “Installed Options”.

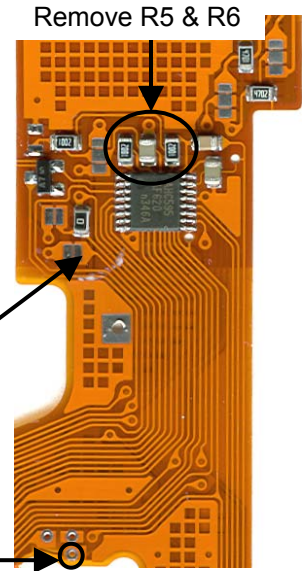
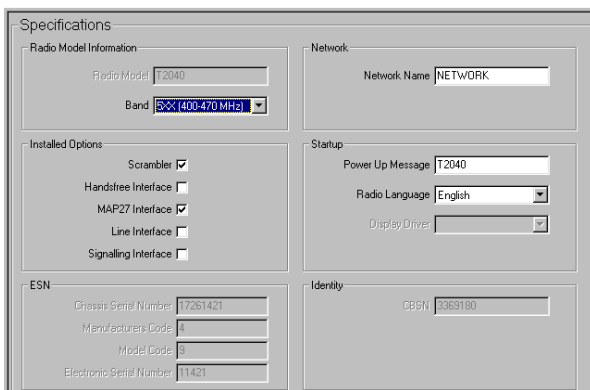

Flex Not Installed: If the flex is not installed, please reference the Service Manual for Tait Encryption for installation of the flex. Make certain R5 and R6 are removed from the flex. The scrambler plugs onto the flex pads labeled TS1. Lift the latch on the scrambler and plug the scrambler into the flex. Make certain the flex is inserted evenly into the connector. The connector foil should be towards the VPU-12-TAIT PCB. Close the latch.

HARDWARE INSTALLATION

Be certain to follow standard anti-static procedures when handling any of Midian’s products.

Tait Orca Series:

Disassembling the Radio:

Reference the Tait Orca Service Manual for instructions on disassembly of the radio. Use extreme care when disassembling the radio.

Installing the Scrambler:

Flex Installed: Make certain R5 and R6 are removed from the flex. The scrambler plugs onto the flex pads labeled TS1. Lift the latch on the scrambler and plug the scrambler into the flex. Make certain the flex is inserted evenly into the connector. The connector foil should be towards the VPU-12-TAIT PCB. Close the latch.

Reassembling the Radio:

Reference the Tait Orca Service Manual for instructions on assembly of the radio. Use extreme care when assembling the radio.

Tait T-2000 Series:

Disassembling the Radio:

Reference the Tait T-2000 Service Manual for instructions on disassembly of the radio.

Installing the Scrambler:

If installed, it will be necessary to remove S-14 and S-16 connectors. On the diagram below, solder the flex leg to S-14 Pin 6 solder pad. When plugged in this leg should be folded under the flex. Plug the flex onto connector T3K45. On the diagram below, solder the flex leg to S-16 Pin 10 solder pad.

Plug the VPU-12-Tait onto the flex connector. With the component side of the flex facing up, the component side of the scrambler should also be facing up.

When closing the radio the mounting holes on the scrambler should line up with the stand-offs in the radio.

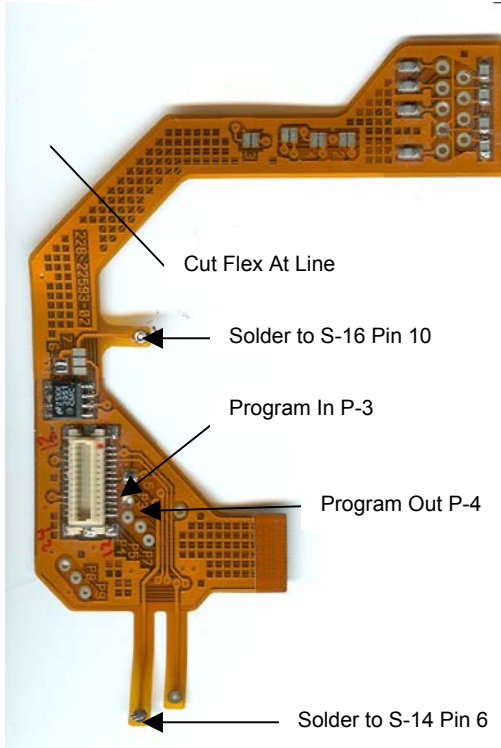

Reassembling the Radio:

Prior to closing the radio the scrambler will need to be programmed, proceed to the programming section. Reference the Tait Orca Service Manual for instructions on assembly of the radio.

NOTE: For more details on installing the flexes into the radios, please reference Tait's Encryption Installation Manual.

PRODUCT PROGRAMMING

Midian's VPU-12-TAIT is programmed via Midian's KL-3 programming cable. Please reference the KL-3 manual for setup instructions of the KL-3 software and hardware. From the product selection screen on the KL-3 UP software, select the VPU-12-TAIT from the list and click OK.

Set the parameters of the VPU-12-TAIT software to fit the application. If any clarifications on a feature are required, move the mouse cursor over the feature name until the question mark appears and right click, a definition of the feature will be shown.

After entering the parameters, save the file by going to File - Save As. Enter the file name in the File Name block and click Save. Saving the file will allow for quick and easy reprogramming of units.

Tait Orca Series:

KL-3 Programming: This feature is not currently available while installed inside the radio.

KL-3 Reading: This feature is not currently available while installed inside the radio.

Tait T-2000 Series:

KL-3 Programming: After plugging the board into the radio, but with the radio still open, connect the black lead of the KL-3 to the radio's chassis, the green clip lead to the Program In hole (P-3), and the yellow clip lead to the Program Out hole (P-4). Turn power on to the radio and click "Program Unit" in the KL-3 software.

KL-3 Reading: Follow the same procedure to read the unit as for programming, but select "Read Unit" in the menu bar. It is necessary to cycle power after programming or reading.

OPERATION

Tait Orca Series:

Display Radios:

Mode Select: Press the Function Key (1, 2, or 3) that was assigned to this function (short or long press). When the scrambler is on "SC" will be indicated on the screen.

Code Select: Press the Function Key (1, 2, or 3) that was assigned to this function (short or long press). Then enter 1 to 16 on the keypad for the desired code followed by pressing the green Menu/Enter button. The display will show "SC01" for instance when the scramble is on with code 1 selected. If the scrambler is off it would show "01".

Non-Display Radios:

Mode Select: Press the Function Key (1 or 2) that was assigned to this function (short or long press). The LED indicates Encryption On/Off status.

Code Select: Code select is not available in this radio.

Tait T-2000 Series:

The function button is used as the scramble/clear (mode) select on this radio. The function button is the button with "Fn" on it. Please note that the button is latched, so only single code operation is available. Program the CLR/SCR Polarity as -/+, so that when the function light is on the scrambler is in scrambled mode.

TECHNICAL NOTES

Radio Compatibility: Midian has taken the utmost care to ensure the option board integrates into the radio with minimal impact to the features of the radio. However, some features may not be available in the radio when an option board is used. If a feature is not available, please contact Midian to see if the feature can be added.

Known Issues:

Tones: Tones such as the programming tones, etc. are not heard in the Tait Orca.

MIDIAN CONTACT INFORMATION

Midian Electronics Inc.
2302 East 22nd Street
Tucson, Arizona 85713 USA

Orders: 1-800-MIDIANS
Phone: 520-884-7981
Fax: 520-884-0422
E-mail: sales@midians.com
Web: <http://www.midians.com/>

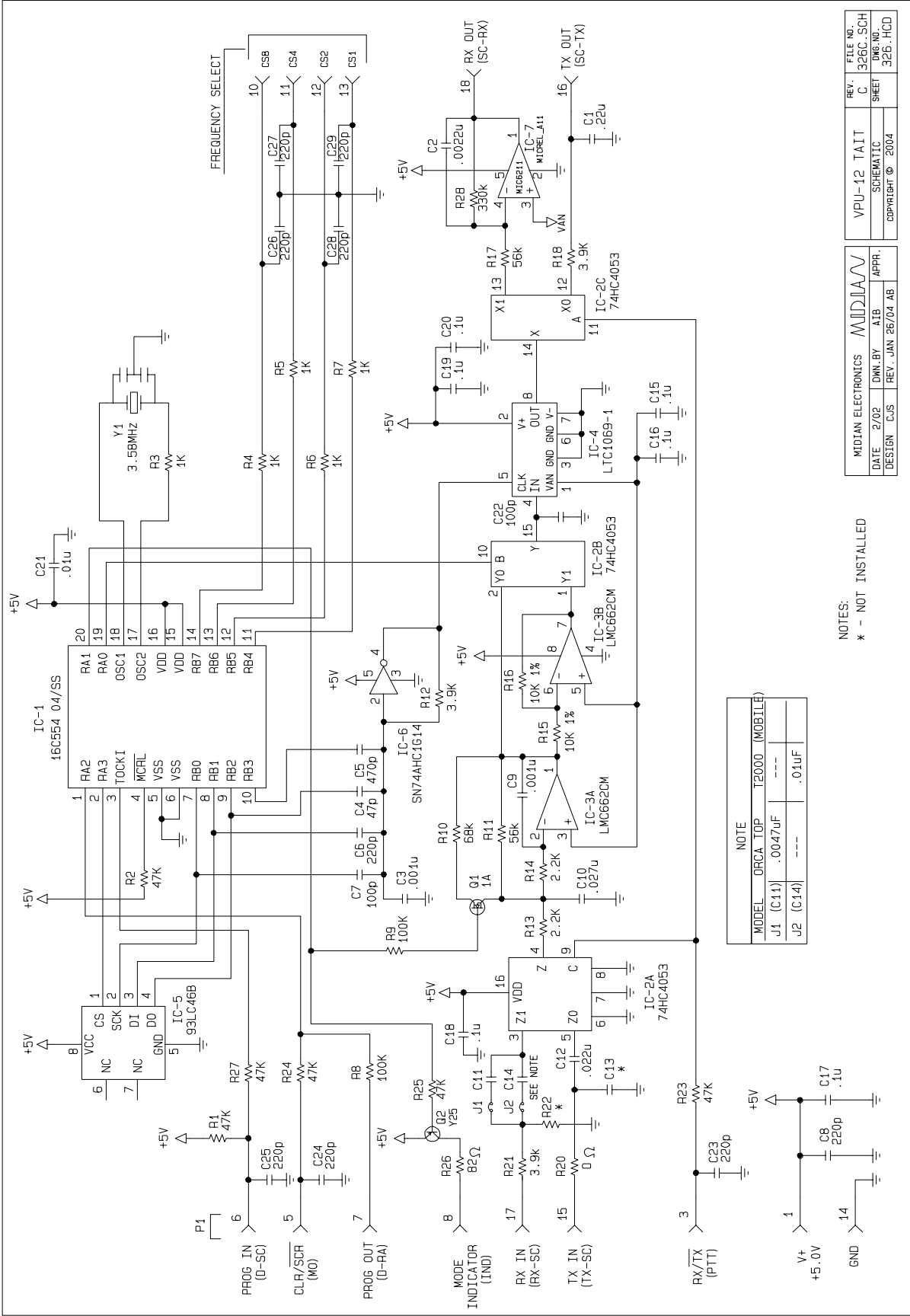

| NOTE | |
|----------|-------------------------|
| MODEL | ORCA TOP T2000 (MOBILE) |
| J1 (C14) | .0047uF --- |
| J2 (C14) | --- .01uF |

NOTES:
* - NOT INSTALLED

| | | | | | |
|--------------------|--------|--------|-------------|-------|------------------|
| DATE | 2/02 | DNW BY | AIB | APPR. | |
| DESIGN | CUS | REV. | JAN 25/04 | AB | |
| MIDIAN ELECTRONICS | MIDIAN | | VPU-12 TAIT | | REV. NO. |
| | | | | | C 396C SCH |
| | | | | | 326.HCD |
| | | | | | SHEET |
| | | | | | 326.HCD |
| | | | | | SCHEMATIC |
| | | | | | REV. 08/04 |
| | | | | | COPYRIGHT © 2004 |

